

GUANGZHOU SOBEY SPORTS CO., LTD.

Address: 209, Building 2, No. 103 Wanhui Second Road, Nancun Town, Panyu district,
Guangzhou, Guangdong Province, China

Tel: 86-(20)38106798 Fax: 86-(20)38106798

<http://www.kumpoo.cn>





TAKE THE CHALLENGE

This is more than just the slogan of Kumpoo, it is also the essence of brand culture. With full confidence and passion, Kumpoo people will create a century-old enterprise and a long-lasting brand with rigorous and pragmatic development concept.

With persistent and innovative spirit of striving, with the business purpose of integrity services, we will depict the brilliant take-off tomorrow for Kumpoo!

GLOBAL STRATEGIC



DISTRIBUTION MAP

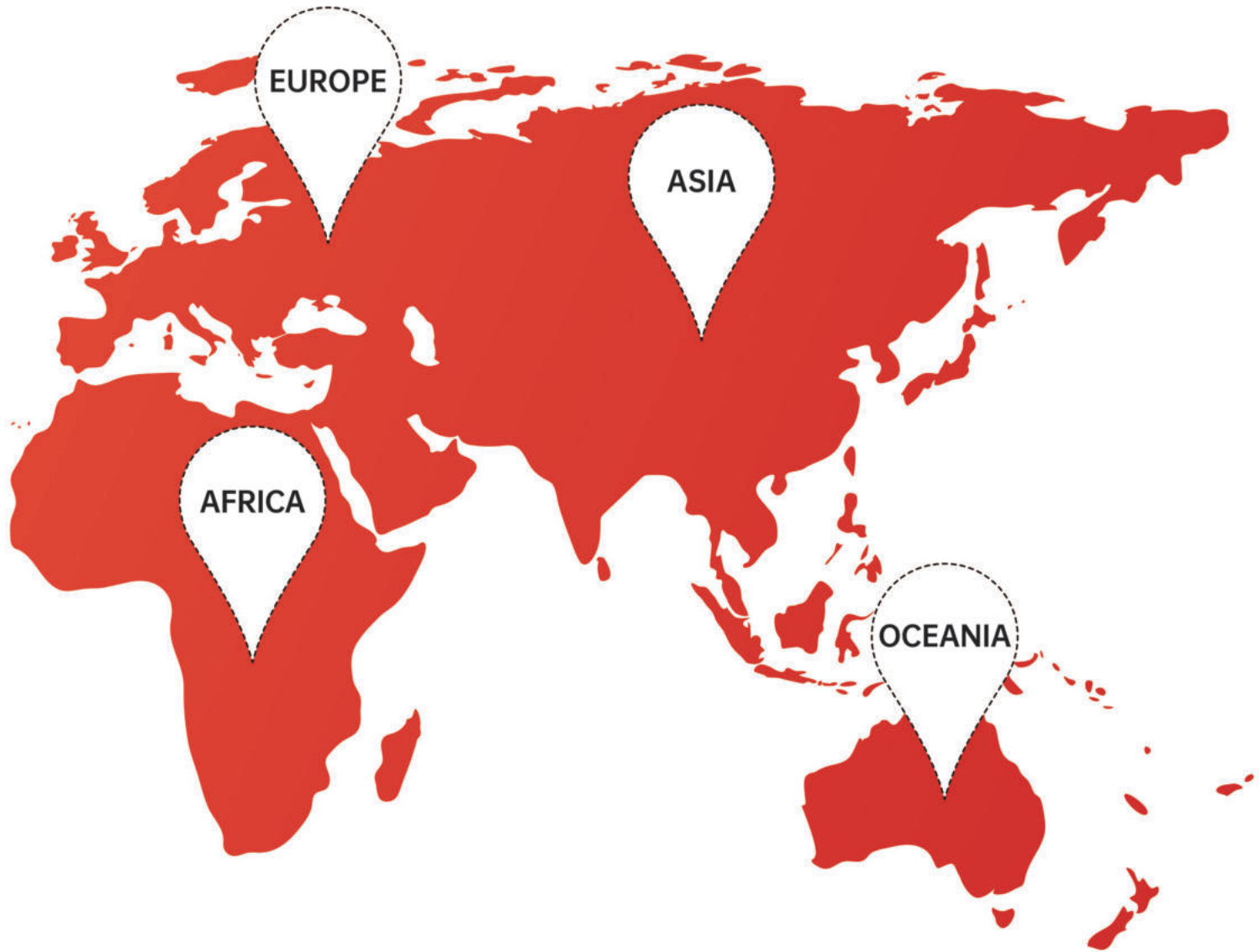



Kantaphon Wangcharoen
Thailand

Racket: ASURA II **Tension:** 32/32

String: JS-67 **Shoes:** KH-G828

Apparel: Tournament Series

2025
Macau Open - Men's Singles Quarter Final

2025
Sudirman Cup Mixed Team Championships - Quarter Final

2024
Japan Open - Men's Singles Quarter Final

Highest World Rank: No.12



Gronya Somerville
Australia

Racket: RIDE THE WIND S (4U)

Tension: 29/31

String: JS-67

Shoes: KH-D72PRO

2025
Sydney International - Women's Doubles Runner-up

2025
Oceania Championships - Mixed Doubles Champion

2024
Oceania Championships - Mixed Doubles Champion

Highest World Rank: No.18

Cheam June Wei
Malaysia

Racket: ASURA II **Tension:** 32/32

String: JS-67 **Shoes:** KH-G828

Apparel: Tournament Series

2025
Lin Dan Cup Chenzhou Station - Men's Singles Champion

2024
Lin Dan Cup Macau Station - Men's Singles Champion

2024
Kaohsiung Masters - Men's Singles Runner-up

Highest World Rank: No.41



Kalle Koljonen
Finland

Racket: ASURA II **Tension:** 31/31

String: JS-63 **Shoes:** KH-G826S

Apparel: Tournament Series

2025
Hylo Open - Men's Singles Semi Final

2024
Azerbaijan International - Men's Singles Semi Final

2023
Polish Open - Men's Singles Runner-up

Highest World Rank: No.47



Catherine Choi
Canada

Racket:
HYPER SHOT NEX

Tension: String: Shoes:
29/31 JS-65 KH-G828

Apparel:
Tournament Series

2025
Pan American Cup - Team Champion

2024
Azerbaijan International - Women's Doubles
Runner-up

2023
Pan American Games - Women's Doubles
Champion

Highest World Rank: No.27



Lwi Sheng Hao & Chia Wei Jie
Malaysia

Lwi Sheng Hao

Racket:
ASURA II

Tension:
31/31

String:
JS-65

Shoes:
KH-G828

Apparel:
Tournament Series

2025
SYED MODI India International - Men's Doubles Runner-up

2025
Malaysia Super 100 - Men's Doubles Runner-up

2024
Guwahati Masters - Men's Doubles Champion

Highest World Rank: No.36

Chia Wei Jie

Racket:
ASURA II

Tension:
29/29

String:
JS-63

Shoes:
KH-G828

Apparel:
Tournament Series



Chan Yin Chak
Hong Kong, China

Racket: Tension:
ASURA II 31/33

String: Shoes:
JS-65 KH-G828

Apparel:
Tournament Series

2025
Hong Kong Annual Badminton Championships
- (High-level) Men's Singles Champion

2025
Hong Kong Annual Badminton Championships
- (High-level) Men's Doubles Champion

2024
Lin Dan Cup Xinchang Station - Men's Singles
Bronze Medal

Highest World Rank: No.67



Nozomi Shimizu
Australia

Racket:
HYPER SHOT WIND (4U)

Tension: String: Shoes:
28/28 JS-65 KH-G826

Apparel:
Tournament Series

2025
North Harbour International - Mixed Doubles Runner-up

2025
Australian National Championships - Mixed Doubles
Champion

2024
Finnish International - Women's Doubles Champion

Highest World Rank: No.74



Tiffany Ho
Australia

Racket:
HYPER SHOT WIND (4U)

Tension: 26/27 **String:** JS-67

Shoes: KH-G828 **Apparel:** Tournament Series

2025
Australian National Championships - Women's Singles Champion

2024
Paris Olympic Games (Badminton) - Women's Singles Qualifier

2024
Oceania Championships - Women's Singles Champion

Highest World Rank: No.78



Karono Karono
Australia

Racket: HOUYI III **Tension:** 28/28

String: JS-63 **Shoes:** KH-G826S

Apparel:
Tournament Series

2024
Welsh International Open - Men's Singles Champion

2024
North Harbour International - Men's Singles Champion

Highest World Rank: No.134



Dalila Aghnia Puteri
Indonesia

Racket:
RIDE THE WIND (6U)

Tension: 30/31 **String:** JS-65 **Shoes:** KH-D72PRO

Apparel:
Tournament Series

2025
Ghana International - Women's Singles Semi Final

2025
Dutch Open - Women's Singles Quarter Final

Highest World Rank: No.167



Korakrit Laotrakul
Thailand

Racket:
2300-DAREN II

String: JS-65 **Tension:** 32/32 **Shoes:** KH-G828

Apparel:
Tournament Series

2025
Malaysia Super 100 - Men's Singles Round 16

2024
Vietnam Badminton International Series - Men's Singles Round 16

2022
Swedish Open - Men's Singles Semi Final

Highest World Rank: No.168



Faye Huo
Australia

Racket:
HYPER SHOT WIND (4U)

Tension: 26/27 **String:** JS-63

Shoes: KH-D72PRO **Apparel:** Tournament Series

2025
Oceania Championships - Women's Singles Runner-up

2025
Oceania Junior Team Championships - Qualifier

2024
Australian National Championships - U17 Mixed Doubles Champion

Highest World Rank: No.174



Maureen Wijaya
Australia

Racket:
HYPER SHOT WIND (4U)

Tension: 28/28 **String:** JS-65

Shoes: KH-G826 **Apparel:** Tournament Series

2025
Oceania Championships - Women's Doubles Runner-up

2025
Oceania Junior Team Championships - Qualifier

2023
Australian National Championships - U17 Women's Doubles Champion

Highest World Rank: No.208



K1 INTERNATIONAL
BADMINTON CLUB

K1 INTERNATIONAL BADMINTON CLUB

2025

Lin Dan Cup Jinzhou Station Men's Singles Champion - Cheam June Wei
Latvia International Challenge 2025 - Men's Singles Champion
"THE BLACK VALLEY CUP" International Badminton Challenge - Team Champion
KUMPOO "NO FEAR OF CHALLENGE" Tournament Guangzhou Station - Runner-up
Malaysia International Challenge 2025 - Men's Doubles 3rd place

2024

Lin Dan Cup Macau Station Men's Singles Champion - Cheam June Wei
Lin Dan Cup Shen Zhen Station Men's Singles Champion - Cheam June Wei
Buzzminton International Challenge (Finals) - Champion

HEBEI BADMINTON TEAM

2025

National U12-14 Badminton Championships (North) - U14 Women's Team 3rd place
National U12-14 Badminton Championships (North) - U14 Women's Singles 3rd place

2024

National U12-14 Badminton Championships (North) -U14 Men's Team Champion
National U12-14 Badminton Championships (Final) - U14 Men's Singles Champion
2024 Badminton Asia U17&U15 Junior Championships - U15 Men's Singles Champion



HEBEI BADMINTON TEAM



PEKING UNIVERSITY BADMINTON TEAM

2025

33rd Capital High-level Universities Badminton Championships - Men's Doubles Runner-up
 33rd Capital High-level Universities Badminton Championships - Women's Doubles Runner-up
 27th National College Students Badminton Championships (High-level) - Women's Team Champion

2024

26th National College Students Badminton Championships (Final) - Women's Team Champion
 32nd Capital High-level Universities Badminton Championships - Men's Team Champion
 26th National College Students Badminton Championships (North) - Men's Team Champion
 26th National College Students Badminton Championships (Final) - Men's Team Runner-up

CENTRAL SOUTH UNIVERSITY BADMINTON TEAM

2025

National College Students Badminton Championships (South) - Women's Singles Champion
 National College Students Badminton Championships (South) - Women's Team 5th place

2024

Hunan College Students Championships - 9 Champions
 National College Students Badminton Championships (High-level) - South Women's Team 3rd place
 National College Students Badminton Championships (High-level) - South Men's Team 5th place





WUHAN SPORTS UNIVERSITY BADMINTON TEAM

2025

Hubei University Badminton Championships - Mixed Doubles Champion

National College Students Badminton Championships (South) - Mixed Doubles 3rd place

2024

Hubei University Badminton Championships - Mixed Doubles Champion

National Sports University Badminton Championships - Men's Team Champion

National Sports University Badminton Championships - Men's Singles Champion

National Sports University Badminton Championships - Men's Doubles Champion



TIANJIN UNIVERSITY BADMINTON TEAM

2024

26th National College Students Badminton Championships (North) - CUBA Men's Team Champion

26th National College Students Badminton Championships (North) - CUBA Men's Doubles 2nd Place



SHIJIAZHUANG TIEDAO UNIVERSITY BADMINTON TEAM

2025

Shijiazhuang College Students Badminton Championship - Mixed Doubles Champion

Shijiazhuang College Students Badminton Championship - Mixed Doubles Champion

2024

Hebei College Students Badminton Championships - Runner-up

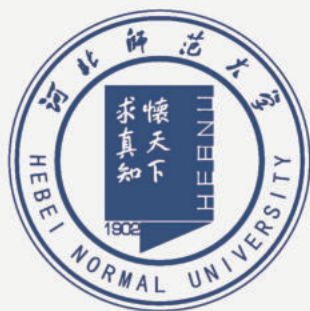

HEBEI NORMAL UNIVERSITY BADMINTON TEAM

2024

Hebei College Students Badminton Championships - Team's 6th Place



HEBEI AGRICULTURAL UNIVERSITY BADMINTON TEAM

珠海市体育运动学校

ZHUHAI SPORTS SCHOOL BADMINTON TEAM

2025

Guangzhou Junior Badminton Championships - Team's Champion of Group C

Guangzhou Junior Badminton Championships - Men's Singles Runner-up of Group A

Guangzhou Junior Badminton Championships - Men's Doubles Runner-up of Group C

2024

Guangzhou Junior Badminton Championships - Team's 5th place of Group A

KUMPOO PRODUCT CATALOG —

CONTENTS
CONTENTS
CONTENTS

— FOR 2026

RACKET SERIES 016

SHOE SERIES 054

BADMINTON STRING SERIES 085

SHUTTLECOCK SERIES 091

APPAREL SERIES 095

JUNIOR SERIES 120

25TH ANNIVERSARY SERIES 134

BAG SERIES 148

ACCESSORY SERIES 177

COURT EQUIPMENT SERIES 187

TAKE THE CHALLENGE

RACKET SERIES

2026
KUMPOO

PRODUCT
CATALOG



RACKET SERIES

TAKE THE CHALLENGE

TAKE THE CHALLENGE

TAKE THE CHALLENGE



LIMITED GIFT BOX
2026 YEAR OF HORSE



NEW



2026 YEAR OF HORSE

Arrival time: January 2026

Frame material: High strength carbon fiber

Shaft material: High strength carbon fiber

Weight/Grip: 4U/G5

Tension: ≤32LBS

Color: Red



Gift Box

Made of high strength carbon fiber, high balance makes your smashes more powerful and stable, own the court in the new coming year.



ASURA II

YUNIPRO

THE UNSTOPPABLE

SUPERFINE
SHAFT

SUPER FINE SHAFT



ENERGY CORED

M50

M50 CARBON FIBER



SHOCK ABSORPTION SYSTEM

FLAGSHIP SERIES - OFFENSIVE



ASURA II

Frame material: New high modulus carbon fiber+
Inner foaming+Nano-Resin

Shaft material: M50 high modulus carbon fiber+
Super fine solid shaft

Weight/Grip: 4U/G5

Tension: ≤32LBS

Color: Red

Unleash unstoppable power with aggressive offense. It features new generation M50 carbon yarn combined with High Stacked Carbon Fiber Composite technology, redefining the aesthetics of powerful attack.

ASURA II SPIKE X

Arrival time: To be confirmed

Frame material: New high modulus carbon fiber+
Inner foaming+Nano-Resin

Shaft material: M50 High modulus carbon fiber+
5.8MM solid shaft

Weight/Grip: 4U/G5

Tension: ≤32LBS

Color: Orange

Follow up the victory, strike for the victory. It features a 5.8mm hard slim shaft combined with high strength carbon fiber, offering best anti-torsional performance and hit feeling.

2300 DAREN II SP 2300 DAREN II SP 2300 DAREN II SP

2300 DAREN II SP 2300 DAREN II SP 2300 DAREN II SP

2300 DAREN II

SP

HEXAGON Shaft | High Stacked Carbon Cloth Composite | 40T High Modulus Carbon Fiber | Dual Frame

FLAGSHIP SERIES - OFFENSIVE

NEW



Patent No.: ZL200820201080.7

2300-DAREN II SP

Arrival time: To be confirmed

Frame material: High modulus carbon fiber+Nano-Resin

Shaft material: High modulus carbon fiber

Weight/Grip: 4U/G5

Tension: ≤ 35 LBS

Color: Yellow/black



Bag

The HEXAGON shaft, paired with a forward-shifted balance point, transforms dynamic design into precise power, embodying professional-level offensive aesthetics.



TAKE THE CHALLENGE

NEW

山 · 海

河北省队

Kumpoo

Kumpoo

MOUNTAINS AND RIVER

NEW

| T1000 High Modulus Carbon Fiber | High Composite Density Shock Absorption System |  ^{TECH} PLIERS PRO |

FLAGSHIP SERIES - OFFENSIVE

NEW



Patent No.:ZL202220048813.8

MOUNTAINS AND RIVERS NEW

Arrival time: March 2026

Frame material: High modulus carbon fiber+Inner foaming

Shaft material: High modulus carbon fiber

Weight/Grip: 4U/G5

Tension: ≤ 35 LBS

Color: White/black



Bag

With T1000+40T materials, box frame and PLIERS PRO technology, it transforms the power into the smashes — delivering a truly professional balance of attack and defense.

FLAGSHIP SERIES - OFFENSIVE

NEW



EX-100

Arrival time: March 2026

Frame material: High strength carbon fiber

Shaft material: High strength carbon fiber

Weight/Grip: 4U/G5

Tension: ≤ 32 LBS

Color: Yellow



Bag

Crafted with high strength carbon fiber and a slim 6.8 mm shaft, it delivers explosive smashes and precise control — empowering you to strike with high-energy dominance on the court.

FLAGSHIP SERIES - OFFENSIVE



Bag



Flannelette Bag

Patent No.:ZL202320834705.8

TWIN-ENGINE II

Frame material: T800 High modulus carbon fiber+
Inner foaming+Nano-Resin
Shaft material: High modulus carbon fiber+Energy core
Weight/Grip: 4U/G5
Tension: ≤32LBS
Color: Purple

The combination of T800 carbon fiber and Nano-Resin improves the anti-torsion, stability and durability.

AK7 II

Frame material: High strength carbon fiber
Shaft material: High strength carbon fiber
Weight/Grip: 4U/G5; 5U/G5
Tension: ≤30LBS
Color: White

Kumpoo innovative front cap reduces 25% of resistance, offering more power.



**HOU
YI
III
SP**

Kumpoo

GRAPHENE / Built-in Titanium Wire / High Modulus Carbon Fiber
High Composite Density Shock Absorption System



FLAGSHIP SERIES - SPEED



HOUYI III SP

Arrival time: To be confirmed

Frame material: High modulus carbon fiber+Graphene+
Inner forming

Shaft material: High modulus carbon fiber+
Built-in titanium wire

Weight/Grip: 4U/G5

Tension: ≤35LBS

Color: Purple

With a 46T material shaft reinforced by a titanium core triangle, TORAY carbon fiber, and the special front cap, it redefines the aesthetics of speed through precision engineering.



HOUYI III

Frame material: High modulus carbon fiber+Graphene+
Nano-Resin

Shaft material: High modulus carbon fiber+
Built-in titanium wire

Weight/Grip: 4U/G5

Tension: ≤35LBS

Color: Gold

It has unstoppable attack and improved speed. Made of TORAY carbon fiber, the racket frame has been optimized to provide both speed and stability.



WHIPBLAST K7

- Titanium Alloy
- Aerodynamic Frame
- High Composite Density Shock Absorption System
- Special Front Cap

SUPER FINE SOLID SHAFT

FLAGSHIP SERIES - SPEED

NEW



WHIPBLAST K7

Arrival time: April 2026

Frame material: High strength carbon fiber+ Titanium alloy+Inner foaming

Shaft material: High strength carbon fiber

Weight/Grip: 4U/G5

Tension: ≤32LBS

Color: Pink



Bag

Titanium alloy frame ensures stable protection, while the aero frame enhances whipping effect, achieving speed and control, helping to deliver decisive shots.

FLAGSHIP SERIES - ALL ROUND



Patent No.:ZL200820201080.7

2300 DAREN II

Frame material: High modulus carbon fiber+Nano-Resin

Shaft material: High modulus carbon fiber+Nano-Resin

Weight/Grip: 4U/G5

Tension: ≤35LBS

Color: Blue



Bag

Balance point has been shifted forward to further enhance offensive performance, making HEXAGON synonymous with relentless attacking power.

FLAGSHIP SERIES - CONTROL



Patent No.: ZL200820201080.7

2900 II

Frame material:	High modulus carbon fiber+Nano-Resin
Shaft material:	High modulus carbon fiber+Nano-Resin+ HEXAGON & Golf shaft
Weight/Grip:	4U/G5
Tension:	≤35LBS
Color:	Gold



Bag

Featuring a golf shaft paired with HEXAGON technology, it boosts hitting speed by 10%. The fully sword frame design reduces swing resistance by 35%, making it ideal for speed-focused players.

RIDE THE WIND 100



6.6MM Slim Shaft

40T High Strength Carbon Fiber

High Composite Density Shock Absorption System

Kump

Kump

FLAGSHIP SERIES - ULTRA LIGHTWEIGHT

NEW



RIDE THE WIND 100

Arrival time: To be confirmed

- Frame material: High strength carbon fiber+Inner foaming
- Shaft material: 40T High strength carbon fiber
- Weight/Grip: 4U/G5
- Tension: ≤35LBS
- Color: Purple; Pink



Bag

Inner foaming combined with the 40T shaft delivers a crisp, stable feeling and rapid rebound, perfectly complementing the playing style of female players.

FLAGSHIP SERIES - ULTRA LIGHTWEIGHT



Bag

RIDE THE WIND S (4U)

Frame material: High strength carbon fiber

Shaft material: Full carbon fiber

Weight/Grip: 4U/G5

Tension: ≤30LBS

Color: White; Gray; Blue

All-round lightweight racket offers smooth and stable control.



Bag

RIDE THE WIND S (6U)

Frame material: High strength carbon fiber

Shaft material: Carbon fiber+Kevlar

Weight/Grip: 6U/G6

Tension: ≤30LBS

Color: Green

Lightweight strikes, swift response.

FLAGSHIP SERIES - ULTRA LIGHTWEIGHT



LORIE 10

- Frame material: Full carbon fiber
- Shaft material: Full carbon fiber
- Weight/Grip: 5U/G6
- Tension: ≤30LBS
- Color: Blue; Pink



Flannelette Bag

Light weight but high elasticity, expanded sweet area, ideal for beginners and female players.

CULTURAL SERIES

NEW



GF-SH

Arrival time: March 2026

Frame material: High strength carbon fiber

Shaft material: High strength carbon fiber

Weight/Grip: 4U/G5

Tension: ≤ 30 LBS

Color: Green



Flannelette Bag

The special front cap significantly reduces air resistance. Paired with the 24T flexible shaft, it transforms ancient mystique into a precise and easily controlled hitting experience.

CULTURAL SERIES



Flannelette Bag



Flannelette Bag

YANGZHOU

Frame material: High strength carbon fiber

Shaft material: High strength carbon fiber

Weight/Grip: 4U/G5

Tension: ≤30LBS

Color: Green

The shaft delivers quick and agile responses, while the box frame ensures stability and control. Suitable for an all-round player.

JINGZHOU

Frame material: High strength carbon fiber

Shaft material: High strength carbon fiber

Weight/Grip: 4U/G5

Tension: ≤30LBS

Color: Light green

The shaft delivers quick and agile responses, while the box frame ensures stability and control. Suitable for an all-round player.

CULTURAL SERIES



Flannelette Bag



Flannelette Bag

DREAM

Frame material: High strength carbon fiber
Shaft material: High strength carbon fiber
Weight/Grip: 5U/G6
Tension: ≤30LBS
Color: White; Pink

High quality full carbon fiber delivers exceptional power and durability. The special paint shines variously as the light change.

PINES II

Frame material: High strength carbon fiber
Shaft material: High strength carbon fiber
Weight/Grip: 4U/G5
Tension: ≤32LBS
Color: White/blue; White/pink

Upgraded materials, enhanced torsion resistance, higher string tension. Featuring a 6.8mm shaft, delivering fast drives and powerful smashes.

QF SERIES

NEW



Flannelette Bag

NEW



Flannelette Bag

QF-TY

Arrival time: March 2026

Frame material: Full carbon fiber
Shaft material: Full carbon fiber
Weight/Grip: 4U/G5
Tension: ≤30LBS
Color: Blue/red

It features a stable flexibility, suitable for beginners.

QF-R20

Arrival time: March 2026

Frame material: Full carbon fiber
Shaft material: Full carbon fiber
Weight/Grip: 4U/G5
Tension: ≤30LBS
Color: Light purple; Dark blue

It features a stable flexibility, suitable for beginners.

QF SERIES



Flannelette Bag

QF-10

Frame material: Full carbon fiber
Shaft material: Full carbon fiber
Weight/Grip: 5U/G5
Tension: ≤30LBS
Color: White/blue; White/purple; White/green

Ultra-lightweight for agile offense, ideal for beginners and advanced players.



Flannelette Bag

QF-11

Frame material: Full carbon fiber
Shaft material: Full carbon fiber
Weight/Grip: 4U/G5
Tension: ≤28LBS
Color: Pink; Blue

Easy to master and control, ideal for beginners.

QF SERIES



Flannelette Bag

QF-12

Frame material: Full carbon fiber
Shaft material: Full carbon fiber
Weight/Grip: 4U/G5
Tension: ≤28LBS
Color: Silver/green; Silver/pink

Easy to master and control, ideal for beginners.



Flannelette Bag

QF-13

Frame material: Full carbon fiber
Shaft material: Full carbon fiber
Weight/Grip: 4U/G5
Tension: ≤28LBS
Color: Pink; Blue

Easy to master and control, ideal for beginners.

KZ SERIES

NEW



Flannelette Bag

NEW



Flannelette Bag

KZ-HD

Arrival time: March 2026

- Frame material: Full carbon fiber
- Shaft material: High strength carbon fiber+Inner foaming
- Weight/Grip: 4U/G5
- Tension: ≤30LBS
- Color: Black

The box frame and inner foaming shaft absorb vibrations together. High-strength grommets and best balance point transform power into a solid feel, offering both attack and defense capability, helping beginners stay composed through every rally.

KZ-10

Arrival time: March 2026

- Frame material: Full carbon fiber
- Shaft material: High strength carbon fiber+Inner foaming
- Weight/Grip: 4U/G5
- Tension: ≤30LBS
- Color: Dark blue; White

Box frame and best balance point provide good stability and solid feedback.

MC SERIES



Flannelette Bag

MC66

Frame material: Full carbon fiber
Shaft material: Full carbon fiber
Weight/Grip: 4U/G5
Tension: ≤28LBS
Color: Blue

Perfect balance point, large sweet area.



Flannelette Bag

MC77

Frame material: Full carbon fiber
Shaft material: Full carbon fiber
Weight/Grip: 4U/G5
Tension: ≤28LBS
Color: Green

Perfect balance point, large sweet area.



Flannelette Bag

MC88

Frame material: Full carbon fiber
Shaft material: Full carbon fiber
Weight/Grip: 4U/G5
Tension: ≤28LBS
Color: Brown

Perfect balance point, large sweet area.

PROMOTION SERIES



K520PRO

Frame material: Full carbon fiber

Shaft material: Full carbon fiber

Weight/Grip: 4U/G5

Tension: ≤ 30 LBS

Color: Pink; Blue; White; Black



Flannelette Bag

PROMOTION SERIES



Flannelette Bag

NEW



Flannelette Bag

VELURIYAM

Frame material: Full carbon fiber
Shaft material: Full carbon fiber
Weight/Grip: 5U/G6
Tension: ≤30LBS
Color: White/purple; White/blue

Suitable for beginners.

CA-17

Arrival time: May 2026

Frame material: Aluminum
Shaft material: Carbon fiber
Weight/Grip: 4U/G5
Tension: ≤24LBS
Color: Blue; Pink

EXCLUSIVE SERIES FOR INTERNATIONAL MARKET



Flannelette Bag

HYPER SHOT NEX

Frame material: High strength carbon fiber+Inner forming
Shaft material: High strength carbon fiber
Weight/Grip: 3U/G5; 4U/G5
Tension: ≤30LBS
Color: Orange; Blue

Featured with 50T high strength carbon fiber and box frame, it offers extra powerful smashes and accurate controls, ideal for players demanding fast swing and offensive performance.



Flannelette Bag

Patent Application Number: 2025222027664

HYPER SHOT HEXAGON

Frame material: High strength carbon fiber
Shaft material: High strength carbon fiber
Weight/Grip: 3U/G5; 4U/G5
Tension: ≤30LBS
Color: Black/red; Black/purple

Featured a patented HEXAGON shaft design, it has enhanced strength and stability while providing powerful torsional resistance, improving shot response time and accuracy.

EXCLUSIVE SERIES FOR INTERNATIONAL MARKET



Flannelette Bag

HYPER SHOT WIND (4U)

Frame material: High strength carbon fiber
 Shaft material: High strength carbon fiber
 Weight/Grip: 4U/G5
 Tension: ≤30LBS
 Color: Rose gold

Featured with high strength carbon fiber, it offers stable and precise control experience.



Flannelette Bag

HYPER SHOT WIND (6U)

Frame material: High strength carbon fiber
 Shaft material: High strength carbon fiber
 Weight/Grip: 6U/G6
 Tension: ≤30LBS
 Color: Purple

72g lightweight enables you to swing faster and do more accurate shots.



Flannelette Bag

HYPER SHOT WIND (8U)

Frame material: High strength carbon fiber
 Shaft material: High strength carbon fiber
 Weight/Grip: 8U/G6
 Tension: ≤28LBS
 Color: Blue

65g lightweight enables you to swing faster and do more accurate shots.



CA-06

Frame material: Carbon Aluminum
Shaft material: Full carbon fiber
Weight/Grip: 3U/G5
Tension: 18-24LBS
Color: Red; Green



Red side



Green side

1 pair/set, strung with 22lbs.

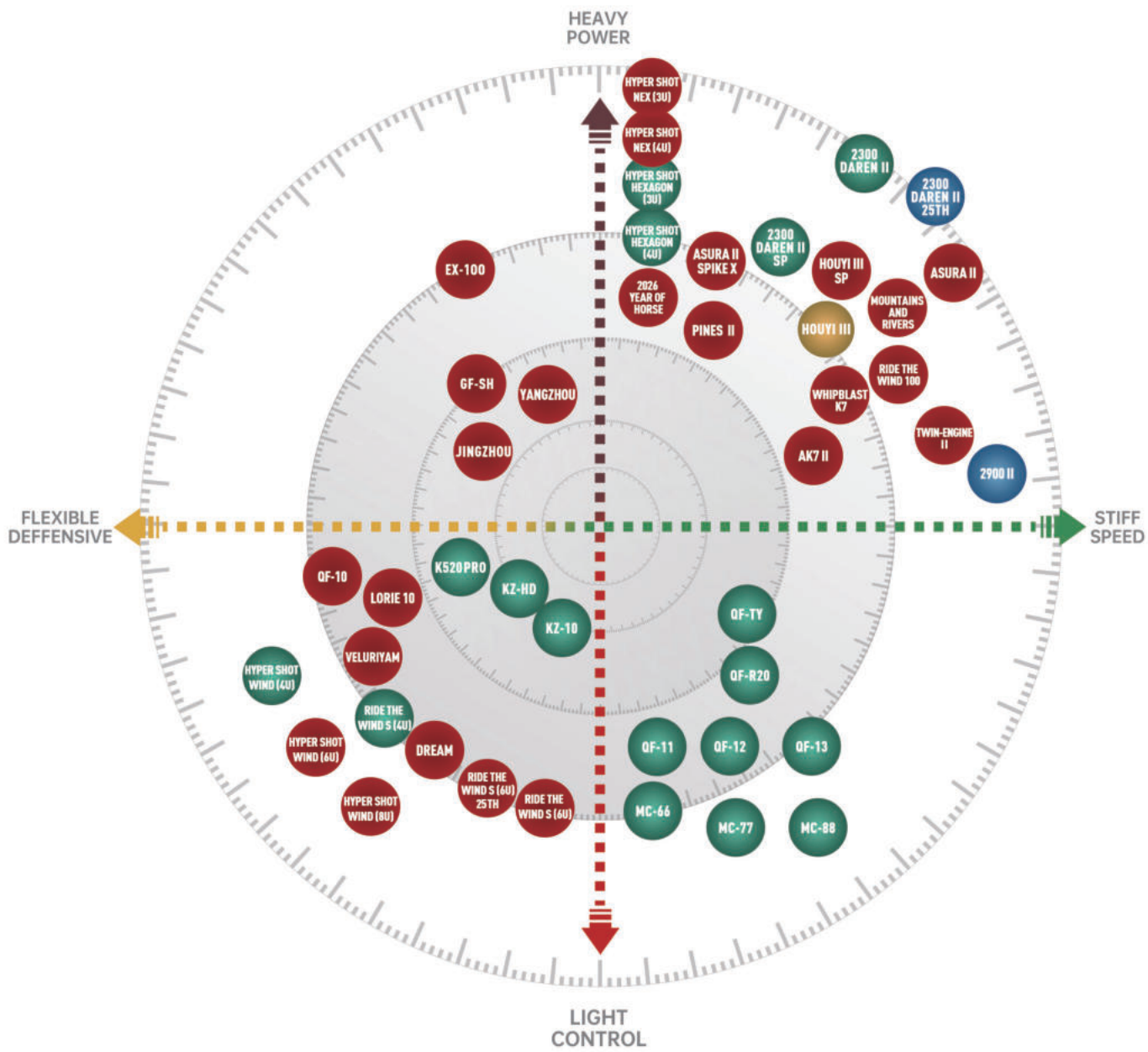

- OFFENSIVE
- ALL-ROUND
- CONTROL
- SPEED

RACKET TECHNOLOGY



EAN ANTI-FAKE TECH

Built-in unique ID chip on the bottom cap, making it more difficult to replicate or tamper, offering near absolute anti-counterfeit protection. Take out the phone and use NFC function to verify its authenticity.



GOLF SHAFT

Kumpoo cooperated with FUJIKURA which was the most professional golf shaft manufacturer in Japan of badminton shaft. It can adjust the bending point of hitting effectively by keeping the same inner and external diameter of the shaft to satisfy the diversity demand of players.



DUAL STIFFNESS PATENT SHAFT

It makes a racket both offensive and defensive. There are two different stiffness on both sides of the shaft, offering distinctly different hitting sensations.

Patent No:ZL201420364704.2



10U-TOP LIGHT RACKET IN THE WORLD

54g (as light as an egg), but the tension can withstand up to 30LBS.

Patent No:ZL201922333792.5



SPIRAL FRAME

The inner and outer sides of the frame flow in opposite directions, giving the head frame a strong streamlined feel and reducing air resistance. The racket frame adopts a concave trapezoidal design at above 3 and 9 o'clock, aiming to reduce wind resistance and increase swing speed; the inverted triangle design is adopted at below 3 and 9 o'clock, providing a more stable structure for the racket frame and ensuring stability during the swing.

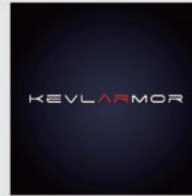

KEVLAR MATERIAL

Kevlar is a strong synthetic fiber that is commonly used in body armor. Kumpoo first applied kevlar to the racket by it combining firmly with carbon fiber to provide higher strength to the frame. The excellent Kevlar avoids making the frame collapse easily and provides more powerful hitting.



GRAPHENE FRAME

Involving the strength of Graphene, Graphene precise technology effectively enhances the frame by reconstructing molecular patterns of carbon fiber and Graphene. This technology makes light weight rackets bear high tension.

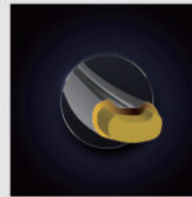

SHOCK ABSORPTION SYSTEM

By using a special process, polyurethane raw material fills into the racket frame and changes into a spongy structure after high temperature and cooling down. It absorbs shock, reduces uncomfortable feelings in arms and improves hitting comfort.

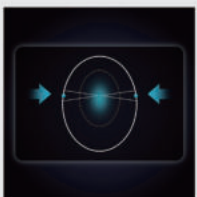

ENERGY COLLECTING AND BALANCE SYSTEM

Located at 3 and 9 o'clock of the frame, precisely controls reset, suppresses racket surface shaking, and enhances racket anti-torsion performance, allowing players to hit back faster, more accurately, and more stably during the second swing.

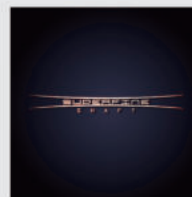

SUPER FINE SHAFT

Kumpoo shafts vary from 6.6mm and 6.5mm to 6.3mm and 6.1mm. And 6.1mm shaft creates a more flexible and quicker hitting experience for the players.

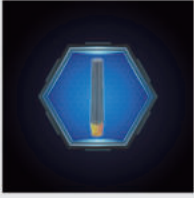

HEXAGON SHAFT

Changing the shaft from a normal round to a hexagonal shape (5cm above the front cap) brings better anti-torsion performance and a more accurate drop point. It can also make the shaft rebound faster and offer the player a quicker reaction.

Patent No:ZL200820201080.7



ENERGY CORED SHAFT

The technology is to implant the specially processed core material into the inner cavity of the traditional shaft. It can absorb shocks from the frame and then improve the hand feeling.

Patent No:ZL202320834705.8



BUILT-IN TITANIUM WIRE BUILT IN TITANIUM

Known as the metal of the future, titanium has the advantages of light weight and high strength. Combined with super high modulus carbon yarn, three memory titanium wire improve the rebound speed of the shaft and anti-torsion performance of the racket.



WOVEN MANUFACTURING

Woven fabric manufacturing is a high-technology process used in high-end badminton rackets. Woven has excellent stability and maintains its best status while hitting, creating rich patterns and beautiful embossing.



PLIERS TECH

By applying 3K carbon cloth, Kumpoo develops a new patented cap, which fastens the shaft tightly. Compared with traditional rackets, the touch area of shaft and cap increases by 25%. The cap fastens the shaft tightly without any wobble and the anti-torsion of shaft increases greatly.

Patent No:ZL202220048813.8



PLIERS TECH PRO

The front cap is upgraded into a unique shape, which provides a better rebound ability for the shaft. Instead of 3K carbon cloth, 1K carbon cloth has a clearer texture. The inside cap is designed with skidproof stripes, which improve firmness between the cap and handle.



CARBON HANDLE

Compared with traditional wooden handle, carbon handle is tougher, lighter, more durable and not easy to erode by sweat. Carbon handle also provides good control and a comfortable feeling for the players.



CHAMELEON PAINT

A special material that can change into different colors under various lights and angles.



INNER FOAMING SHAFT

Through inner PU foaming technology, it breaks through the limitations of traditional heat moulding, making the internal structure of the carbon fiber smoother. This enhances torsional resistance by 10%, allowing for smoother power transfer and more stable performance. The PU foam material attached to the inner significantly reduces vibration feedback to the hand.

TAKE THE CHALLENGE

SHOE SERIES

2026
KUMPOO

PRODUCT
CATALOG

SHOE



TAKE THE CHALLENGE
TAKE THE CHALLENGE
TAKE THE CHALLENGE
TAKE THE CHALLENGE

TAKE THE CHALLENGE
TAKE THE CHALLENGE
TAKE THE CHALLENGE

KH-G805 LITE PRO



ULTRA LIGHTWEIGHT

VELDLITE



A



B



C

Women's Style Size 35-40

KH-G805 LITE PRO

Color:	A-White/navy blue; B-Light blue; C-White/pink
Upper:	Mesh+TPU+PU
Insole and lining:	Fabric+EVA
Sole:	Natural rubber+MD+TPU+Carbon plate+EVA+Mesh+ACF
Size:	35-45#

Arrival time: January 2026



Remark: With shoe bag

Features: Artificial leather / Anti torsion / Lateral wall / ESS EVA / Hyper sole

- The upper is made of PU and TPU, providing lightness, breathability, and stability.
- TPU in the shoe upper maintains support and balance.
- The sole is equipped with a non-slip rubber outsole, ultra-light midsole, TPU and carbon plate.
- Natural rubber sole with three-dimensional pattern, which is wear-resistant and anti-slip.

KH-G815



ULTRA LIGHTWEIGHT

VELDLITE



A



B



C

KH-G815

Color:	A-Black/gold; B-White/silver; C-Green
Upper:	Mesh+TPU+Microfiber
Insole and lining:	Fabric+EVA
Sole:	Natural rubber+MD+TPU+Carbon plate+EVA+Mesh+ACF
Size:	35-45#

Arrival time: May 2026

Remark: With shoe bag

Features: Artificial leather / Anti torsion / Air hole / Lateral wall / ESS EVA / Hyper sole

- The upper features a perforated bonded design, providing lightness, breathability, and support.
- TPU in the shoe upper maintains support and balance.
- The sole is equipped with a non-slip rubber outsole, ultra-light midsole, TPU and carbon plate.
- Natural rubber sole with three-dimensional pattern, which is wear-resistant and anti-slip.

STABLE PROTECTION

DUO
POWER

MUSCLE
PILLAR

ACF

fitgo



A



B



KH-G826S

Color:	A-Silver; B-Gold
Upper:	TPU+Mesh+Flyknit+Fitgo
Insole and lining:	Fabric+EVA
Sole:	Natural rubber+MD+TPU+ACF
Size:	35-46#

Arrival time: January 2026

Remark: With shoe bag

Features: Artificial leather / Double air mesh / Anti torsion / Air hole / DUO POWER / Fitgo / Lateral wall

- The upper is made of PU, TPU and mesh, providing flexibility, lightness, breathability, and support.
- Elastic stocking shell structure, easy to put on and take off, strong wraps.
- Five-dimensional composite outsole and raw rubber sole with three-dimensional pattern design make the shoes anti-torsion, anti-slip, wear resistant and stable.
- Knob button device, adjusting the shoe elasticity is more convenient, faster.

STABLE PROTECTION



A

KH-G826S

Color:	A-White; B-White/red; C-Black
Upper:	TPU+Mesh+Flyknit+Fitgo
Insole and lining:	Fabric+EVA
Sole:	Natural rubber+MD+TPU+ACF
Size:	35-45#



B



C



Remark: With shoe bag & box

Features: Artificial leather / Double air mesh / Anti torsion / DUO POWER / Fitgo / Lateral wall

- The upper is made of TPU and mesh, providing flexibility, lightness, breathability, and support.
- Elastic stocking shell structure, easy to put on and take off, strong wraps.
- Five-dimensional composite outsole and raw rubber sole with three-dimensional pattern design make the shoes anti-torsion, anti-slip, wear-resistant, stable.
- Knob button device, adjusting the shoe elasticity is more convenient, faster.

STABLE PROTECTION

DUO POWER

MUSCLE

ACF



A



B

KH-G826

Color:	A-White/red/black; B-White/green; C-Blue/white
Upper:	TPU+Mesh+Flyknit
Insole and lining:	Fabric+EVA
Sole:	Natural rubber+MD+TPU+ACF
Size:	35-45#



C

Remark: With shoe bag

Features: Artificial leather / Double air mesh / Anti torsion / Air hole / DUO POWER / Lateral wall

- The upper is made of TPU and mesh, providing flexibility, lightness, breathability, and support.
- Elastic stocking shell structure, easy to put on and take off, strong wraps.
- Five-dimensional composite outsole and raw rubber sole with three-dimensional pattern design make the shoes anti-torsion, anti skip, wear resistant and stable.

KH-G828



TAKE THE CHALLENGE



A



B

KH-G828

Color:	A-Black/white; B-Blue
Upper:	Microfiber+TPU+Mesh
Insole and lining:	Fabric+EVA
Sole:	Natural rubber+Supercritical midsole+TPU+Carbon plate+ACF
Size:	35-45#

Remark: With shoe bag

Features: Artificial leather / Double air mesh / Anti torsion / Supercritical midsole / Lateral wall

- Using supercritical foaming midsole technology, the overall is lighter and more textured, offering high impact resistance, excellent rebound performance, and durability.
- The upper is made of synthetic microfiber with a TPU film, providing flexibility, lightness, breathability, and support.
- The rubber outsole features 3D carbon plates at the arch area, combined with a three-dimensional tread design for stable support and slip resistance.
- The W-HOLD anti-torsion system features a robust lateral wrapping structure that powerfully resists excessive foot twisting and deformation.

KH-G715



KH-G715



A



B



C

KH-G715

Color:	A-Purple; B-Blue; C-Green/pink
Upper:	Flyknit+Woven+Mesh+TPU+PU
Insole and lining:	Fabric+EVA
Sole:	Natural rubber+MD+TPU+ESS+Carbon plate
Size:	35-45#

Arrival time: March 2026



Remark: With shoe bag & box

Features: Anti torsion / Air hole / Lateral wall / Hyper sole / TPU Fit

- The upper is made of woven jacquard mesh, providing flexibility, breathability, and comfort.
- The sole is equipped with MD, TPU support structure and ESS shock absorption technology.
- Natural rubber sole with three-dimensional pattern, which is wear-resistant and anti-slip.



LEOBOOM



A



KH-G712

Color:	A-White/purple; B-White/gray/blue
Upper:	UHMWPE+Mesh+TPU+PU
Insole and lining:	Fabric+EVA
Sole:	Natural rubber+LEOBOOM Midsole+TPU+Carbon plate
Size:	35-45#



B

Remark: With shoe bag

Features: UHMWPE / Artificial leather / Double air mesh / Anti torsion / LEOBOOM / Lateral wall

- The upper is made from environmental-friendly UHMWPE, providing flexibility, lightness, breathability, and support.
- The key areas of the shoe upper are layered for enhanced lateral protection and wear resistance.
- The carbon plate outsole, combined with a TPU anti-twist plate and LEOBOOM midsole, features a three-dimensional tread design for stable, anti-slip performance.
- The rubber outsole with a three-dimensional tread design is durable and provides excellent grip.

SPEED



A



KH-D75

Color: A-White/purple; B-White/black; C-White/blue
Upper: Mesh+TPU+PU
Insole and lining: Fabric+EVA
Sole: Natural rubber+LEOBOOM Midsole+TPU+Carbon plate
Size: 35-45#

Arrival time: May 2026



B



C

Remark: With shoe bag

Features: Artificial leather / Double air mesh / Anti torsion / Air hole / LEOBOOM midsole / Lateral wall

- The upper is made of PU, TPU and mesh, providing flexibility, lightness and breathability.
- Special process on the shoe body enhances lateral protection and durability.
- Equipped with carbon plate outsole, combined with a TPU anti-twist plate and LEOBOOM midsole, it features a three-dimensional tread design for stable, anti-slip performance.

SPEED



A

KH-E315

Color: A-White/silver; B-White/red; C-White/blue

Upper: Mesh+TPU+PU

Insole and lining: Fabric+EVA

Sole: Natural rubber+MD+Carbon plate

Size: 35-45#

Arrival time: March 2026



B



C

Remark: With shoe bag

Features: Artificial leather / Anti torsion / ESS EVA / Hyper sole

- The upper is made of super light mesh, providing lightness and breathability.
- TPU in the shoe upper maintains support and balance.
- Natural rubber sole with three-dimensional pattern, which is wear-resistant and anti-slip.

SPEED



A



KH-E316

Color:	A-Blue/orange; B-Green/blue
Upper:	Mesh+TPU+PU
Insole and lining:	Fabric+EVA
Sole:	Natural rubber+MD+Carbon plate
Size:	35-45#

Arrival time: March 2026



B

Remark: With shoe bag

Features: Artificial leather / Anti torsion / ESS EVA / Hyper sole

- The upper is made of PU and mesh, providing lightness and toughness.
- TPU in the shoe upper maintains support and balance.
- Carbon plate is added in the arch area, providing stable support for the sole.
- Natural rubber sole with three-dimensional pattern, which is wear-resistant and anti-slip.

SPEED



A

KH-E317

Color:	A-White/blue; B-White/green
Upper:	Mesh+PU
Insole and lining:	Fabric+EVA
Sole:	Natural rubber+MD+Carbon plate
Size:	35-45#



B

Arrival time: March 2026

Remark: With shoe bag

Features: Artificial leather / Anti torsion / ESS EVA / Hyper sole

- The upper is made of PU and mesh, providing lightness and toughness.
- Carbon plate is added in the arch area, providing stable support for the sole.
- Natural rubber sole with three-dimensional pattern, which is wear-resistant and anti-slip.

SPEED



A

KH-E318

Color:	A-Off-white/pink; B-White/blue
Upper:	Mesh+TPU+PU
Insole and lining:	Fabric+EVA
Sole:	Natural rubber+MD+Carbon plate
Size:	35-45#

Arrival time: May 2026



B

Remark: With shoe bag

Features: Artificial leather / Anti torsion / ESS EVA / Hyper sole

- The upper is made of PU and mesh, providing lightness and toughness.
- TPU in the shoe upper maintains support and balance.
- Carbon plate is added in the arch area, providing stable support for the sole.
- Natural rubber sole with three-dimensional pattern, which is wear-resistant and anti-slip.

SPEED



A



B



C



D

KH-E319

Color:	A-White/blue; B-Gray/silver; C-White/purple; D-White/brown
Upper:	Mesh+PU
Insole and lining:	Fabric+EVA
Sole:	Natural rubber+MD+Carbon plate
Size:	35-45#

Arrival time:	May 2026
---------------	----------

Remark: With shoe bag

Features: Artificial leather / Anti torsion / ESS EVA / Hyper sole

- The upper is made of PU and mesh, providing lightness and toughness.
- Carbon plate is added in the arch area, providing stable support for the sole.
- Natural rubber sole with three-dimensional pattern, which is wear-resistant and anti-slip.

SPEED

LEOBOOM



A



B



C



KH-D72PRO

Color:	A-Purple; B-Pink; C-White/black
Upper:	TPU+PU+Mesh
Insole and lining:	Fabric+EVA
Sole:	Natural rubber+LEOBOOM Midsole+TPU+Carbon plate
Size:	35-45#



Remark: With shoe bag & box

Features: PU / Double air mesh / Anti torsion / LEOBOOM / Lateral wall

- The upper is made of PU, TPU and mesh, providing flexibility, lightness, breathability, and support.
- Laminated membrane compression in shoe to strengthen lateral protection and wear-resistant.
- The carbon plate, TPU anti-distortion piece and LEOBOOM midsole with three-dimensional grain design make the shoes stable and anti-slip.

URBAN LIGHT RUNNING



A



B



C

KH-X107

Color:	A-White; B-Black; C-Pink
Upper:	Mesh+TPU
Insole and lining:	Fabric+EVA
Sole:	Natural rubber+Supercritical midsole
Size:	35-45#

Arrival time: January 2026

Features: Anti-torsion / ESS EVA / Supercritical midsole

- Breathable jacquard for a three-dimensional wrap.
- The upper combines mesh with a TPU structure to achieve a balance of breathability and stability.
- Using supercritical nitrogen-infused foaming midsole, the overall construction is lighter with a premium feel, impact-resistant, highly responsive, and durable.

CASUAL



KH-X007

Color: A-Khaki; B-White/red; C-Black

Upper: EVA

Sole: EVA

Size: 35-44#



Features: Rigid EVA / Hyper sole

- One-piece outsole with lightweight EVA material provides light cushioning.

SHOE TECHNOLOGY



LIGHT PROFESSIONAL BADMINTON SHOES

Kumpoo developed shoes KH-100 in 2009. The new CBS functional rubber and court biting system made the shoes become the lightest in the market.



KPU MATERIAL

Kumpoo was the first to use KPU material in professional badminton shoes, which enhances the wear-resistance, stability and anti-deformation as well as extends the service life.



FITGO

One press and twist, quick lacing! Kumpoo introduces a fast lacing system with tightness accurate to 1mm. With simple knob adjustment the perfect fit tightness is easily achieved. Designed to be durable, the Fitgo can withstand more than 50,000 rotations and pulls of more than 30 kg to ensure long-term reliability.



DUO POWER

The finer the structure, the more delicate the foot feeling! The unique layered design of the DUO POWER has two layers of mid-sole, each with a different density. The outer mid-sole is hard for support and protection; the inner mid-sole is soft for cushioning and comfort.



LEOBOOM MIDSOLE

The LEOBOOM MIDSOLE is created by pressurizing and heating the ETPU material to mimic the state of a cell when it divides. This mid-sole has unparalleled light weight and cushioning performance, and players can feel the explosive power and flexibility of cell division when wearing it.

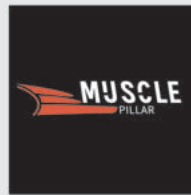

MUSCLE PILLAR

A supporting anti-torsion structure placed on the outsole, inspired by the structure and function of human muscles. The hardness of the muscle pillar is extremely high, even beyond the traditional carbon plate, injecting excellent stability into the badminton shoes. It is specially designed for the arch of the foot, this support structure not only strengthens the arch, but also provides excellent torsion resistance, providing reliable support and sense of safety for the player during every step of the movement.



ACF ARTIFICIAL CARTILAGE FOAM

Mimic the function and structure of cartilage control and adjust its micro-nano structure by physical and chemical methods, so that it is infinitely close to the three-dimensional ultra structure of cartilage, so that we invent a biomimetic material, with the same or better buffer energy absorption effect as cartilage. This innovative material is applied to the midsole and insole of badminton shoes, it can absorb more than 90% of the impact force providing cushioning performance as cartilage.



UHMWPE MATERIAL

Inspired by the bionic structure of silkworm cocoons, this technology uses world-class yarn made from ultra-high molecular weight polyethylene (UHMWPE), offering 2.6 times the elasticity of traditional polyester and 12% lighter than conventional mono yarn. The eco-friendly weaving process breaks away from traditional warp and weft bindings, and the entire process is glue-free, combining the silkworm cocoon-inspired structure for enhanced performance.



SUPERCritical FOAMING MIDSOLE

It adopts supercritical foaming moulding technology, creates a finely structured, uniform foam with tiny, consistent pores. It is lightweight yet high quality. During movement, it offers over 92% energy feedback, with a rebound performance up to 60%, ensuring durability and wear resistance.



W-HOLD

Extending from the forefoot to the heel, the robust lateral wrapping structure provides a stable base for the feet, delivering strong anti-torsion support to resist excessive twisting and deformation, and preventing rollover.



VELOLITE MIDSOLE

It provides an ultimate ground feel and quick start, with anti-rollover and energy cushioning, offering comprehensive traction for various movement modes. It maintains wrapping and comfort while significantly reducing the physical burden on athletes.



Absorbing 90% of the impact force

Mimic the function and structure of cartilage, control and adjust its micro-nano structure by physical and chemical methods, so that it is infinitely close to the three-dimensional ultra structure of cartilage, so that we invent a biomimetic material, with the same or better energy absorption effect as cartilage. This material is applied to the midsole and insole of badminton shoes, it can absorb more than 90% of the impact force.

- Breakthrough cushioning materials for the 21st century

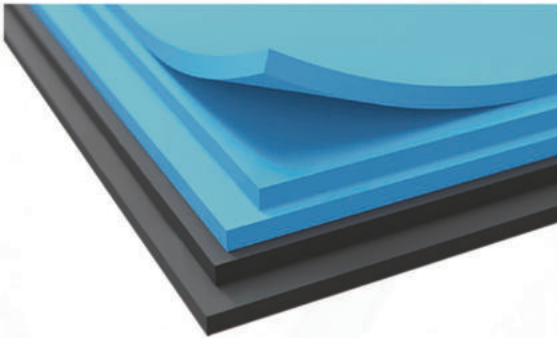

SHOCK IMPACT FROM DIFFERENT MATERIALS

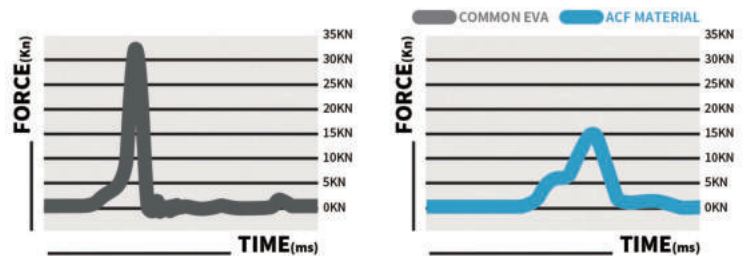

*COMMON EVA

Common EVA material has a high peak force and a large drop, and the impact force quickly declines after reaching the peak, it is easy to injure human body in the force moment.

*ACF MATERIAL

The peak force of ACF is low, and the curve is gentle, reflecting that the impact force is absorbed in large quantities and the impact force is greatly reduced.

- The protecting effect of ACF

COMMON EVA



COMMON EVA

The impact of one to five times body weight is transmitted sequentially from the bottom to the top, and the knee is severely impacted and damaged.

VS

ACF MATERIAL



ACF

Most of the impact is absorbed by the ACF at the bottom of the foot and is not transmitted upwards, maximizing the protection of the knee from injury.

HIGH REBOUND SUPPORT MIDSOLE

The supercritical midsole combined with a TPU anti-torsion support structure targets areas prone to rollover with a lightweight anti-torsion design. It provides stable support for both feet with high rebound performance.



 SUPERCritical
FOAMING MIDSOLE



Persistent rebound
Comprehensive lightweight



Strong support
Comprehensive protection



● Eco-Friendly and Sustainable

The supercritical foaming process eliminates the need for chemical foaming agents, reducing formamide emissions and simplifying production steps. This not only enhances efficiency but also delivers higher material quality.

● High-Performance Energy Feedback

The foam pore structure is fine and evenly distributed. The material delivers over 92% energy return and up to 60% rebound performance. It efficiently absorbs impact, reducing pressure on joints and muscles during movement. The material has an energy feedback rate of over 92% and a rebound performance of up to 60%. It effectively absorbs impact and reduces stress on joints and muscles during exercise. The material better adapts to movement and landing pattern, improving overall comfort. It achieves greater elasticity at a lower density than the industry standard.

● Long-lasting Shock Absorption and Resilience

It offers long-lasting rebound performance with minimal decay, ensuring consistent support over time.

● Ultra-Light Empowerment

Its ultra-light design improves efficiency dramatically.

W-HOLD

- Extending from the forefoot to the heel, the robust lateral wrapping structure provides a stable base for the feet, delivering strong anti-torsion support to resist excessive twisting and deformation.
- The outsole sidewall and the supercritical midsole work together seamlessly to create high-strength support, enabling more precise stopping and directional changes.



High Torsion Resistance
Support feet during movement
Soft inside, tough outside



50° Inner Core Midsole

55° Outer Core Midsole
(Dual Density Shock Absorption)

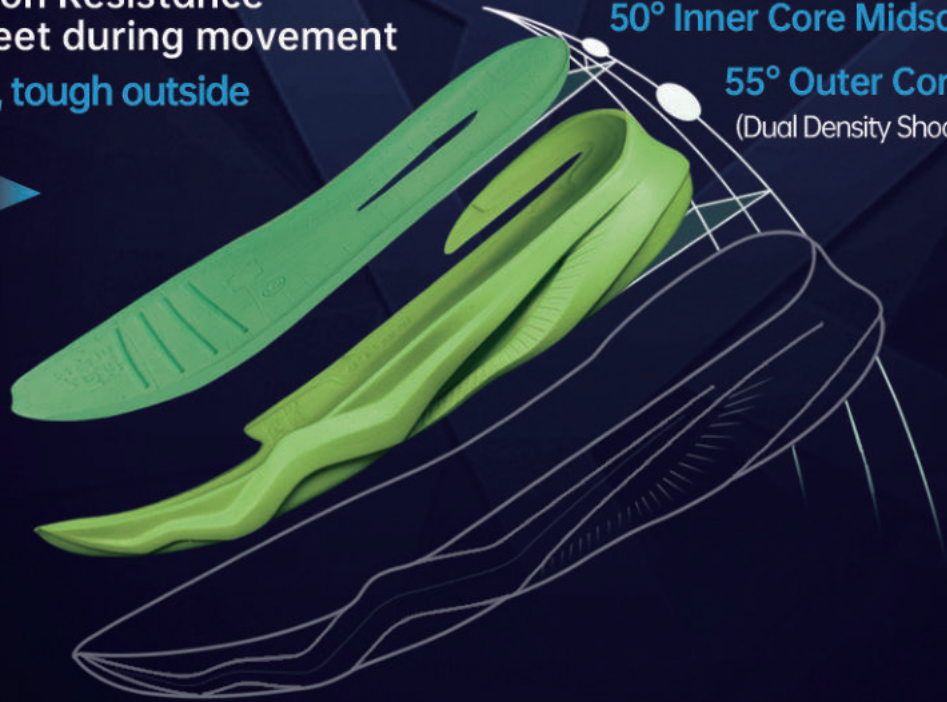

Dual Density Shock Absorption Midsole

> 50° Inner core midsole: offer comfortable feet feeling

> 55° Outer core midsole: provide support and stability

Innovative Design

Dual-layer foam construction: the upper layer features soft material for shock absorption, while the lower layer utilizes firm material for support and stability.

Dual Density

Soft and comfortable while providing strong support and wrapping.

VELOLITE Ultra-thin Outsole

Delivers exceptional feel and explosive acceleration

Ultra-thin Midsole

Ultra-lightweight



STABILITY

Through repeated iterations adjusting the heel curvature and forefoot shape, the initial rollover risk commonly seen in ultra-thin outsoles has been completely resolved.

CUSHIONING

Energy pads embedded in both the forefoot and heel achieve effective shock absorption within a millimeter-level space.

WRAPPING

The full-length midsole delivers dynamic wrap-around support, ensuring that every push-off transfers power efficiently, unifying exceptional fit with comfort.

KI-09 High Elasticity Protective Insole

Breathable surface + High-rebound TPE base

Provides a breathable and comfortable underfoot feel. The full-length TPE cushioning layer absorbs impact upon landing, enhancing overall performance and comfort.



Bionic 3D carbon-pattern framework

Delivers enhanced stability and support, reinforcing the arch area. Helps improve performance, reduce injury risk, and prevent lateral rollover.

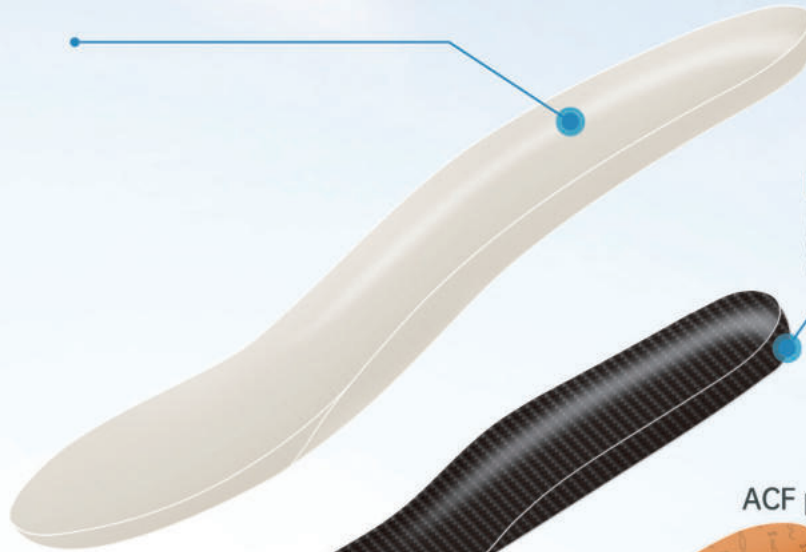

ACF pad



ACF pad

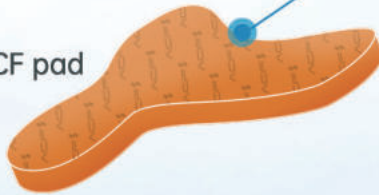

ACF Cushioning pad

Absorbs up to 90% of impact. Reduces vibration generated with each step. Helps minimize muscle and joint fatigue during high-intensity movements.

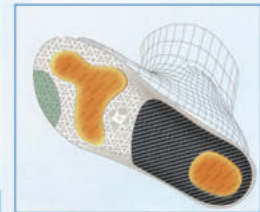

KI-09 Features:

1. Made from high-elastic, breathable materials, the insole feels soft and keeps your feet dry and fresh.
2. The built-in cushioning pad effectively absorbs impact, significantly reducing fatigue during intense movements.
3. Durable and wear-resistant, it maintains its shape over long-term use without collapsing or deforming.

STABLE PROTECTION



KH-G826S



KH-G826S



KH-G826



KH-G825

ALL-ROUND

OFFENSIVE



KH-G715



KH-G712



KH-G828

ULTRA LIGHTWEIGHT



KH-G805



KH-G815

SPEED



KH-D75



KH-E315



KH-E316



KH-E317



KH-318



KH-E319



KH-D72 PRO

Shoes size information (Adopted from the new models since september 2023)

Foot length(mm)	19.0	20.0	20.5	21.0	22.0	22.5	23.0	23.5	24.0	24.5	25.0	25.5	26.0	26.5	27.0	27.5	28.0	28.5	29.0	29.5	30.0
CHN	190 (2.0)	200 (2.0)	205 (2.0)	210 (2.0)	220 (2.0)	225 (2.0)	230 (2.0)	235 (2.0)	240 (2.0)	245 (2.0)	250 (2.0)	255 (2.5)	260 (2.5)	265 (2.5)	270 (2.5)	275 (2.5)	280 (2.5)	285 (2.5)	290 (2.5)	295 (2.5)	300 (2.5)
USA	1	2	2.5	3	4	4.5	5	5.5	6	6.5	7	7.5	8	8.5	9	9.5	10	10.5	11	11.5	12
EUR	31	32	33	34	35	36	37	37.5	38	39	39.5	40	40.5	41	42	43	44	44.5	45	45.5	46

Adult shoes size specification

Foot length(mm)	19.0	20.0	20.5	21.0	22.0	22.5	23.0
CHN	190 (2.0)	200 (2.0)	205 (2.0)	210 (2.0)	220 (2.0)	225 (2.0)	230 (2.0)
USA	1	2	2.5	3	4	4.5	5
EUR	31	32	33	34	35	36	37

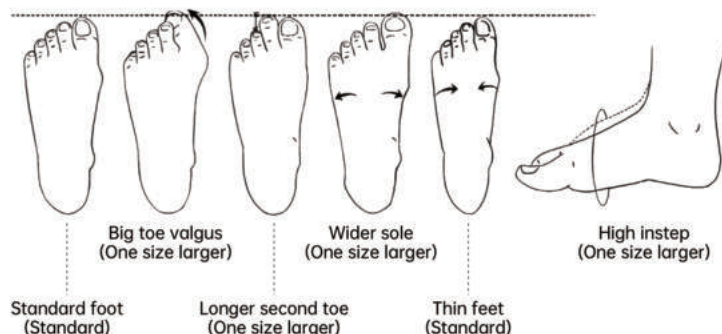

Measurement of foot length

★ Put the foot flat on the white paper, step on the ground vigorously: Use the pen to mark the longest point at the front and back of the foot, and connect these two points together which is the correct foot length.

★ Remark: For customers with thinner and smaller feet, we recommend buying shoes one size smaller.

FUNCTIONS

Microfiber	High rub resistance, light and soft artificial leather, Improving substantially the durability and comfort level.	TPU Fit	Kumpoo TPU FIT technology can avoid the damage of shoes, provide certain ductility during the movement and maintain the package to feet.
Anti torsion	Guaranteeing midsole stability, preventing over deflecting from extreme sports.	Double air Mesh	Double air-mesh improves the ventilation and air permeability.
ESS EVA	Light and high strength. It can enhance the stability of sole during the movement.	3E wide last	Kumpoo developed a special shoes last for Chinese market. Comparing to other brands' 2.5 last, it is more suitable for the East Asians and provides a more comfortable fit.
Super light	Kumpoo has developed a super light rubber and insole which can make the shoes light as well as reaching the rigorous test requirement. It can increase the wear resistance and grip of the shoes.	Lateral wall	Kumpoo's unique molding and patent sole design can prevent the feet spraining.
C.B.S	The latest CBS system makes the lightest professional badminton shoes.	Metallic pu	A kind of special artificial leather which has superior softness, beautiful metal color appearance and excellent comfortable sense.
Hyper sole	Hyper sole and 12mm shock absorbers which are used in the front and heel of shoes will make the shoes more stable and shock absorbers.	Air hole	The six air holes of the sole will increase the ventilation and perspire as well as keep the feet dry and comfortable.
LEOBOOM mid-sole	The LEOBOOM mid-sole is created by pressurizing and heating the ETPU material to mimic the state of a cell when it divides. This mid-sole has unparalleled light weight and cushioning performance, and players can feel the explosive power and flexibility of cell division when wearing it.	DUO POWER	The finer the structure, the more delicate the foot feeling! The unique layered design of the DUO POWER has two layers of midsole, each with a different density. The outer midsole is hard for support and protection; the inner midsole is soft for cushion and comfort.
Knob button	One push and twist for quick lacing! Elasticity can be accurate to 1mm, easy to adjust to the right tightness for you. The device can withstand over 90,000 rotations and 36kg of pulling force, strong and durable.		

TAKE THE CHALLENGE

BADMINTON STRING *SERIES*

2026
KUMPOO

PRODUCT
CATALOG

TAKE THE CHALLENGE TAKE THE CHALLENGE

BA **ON**

TAKE THE CHALLENGE
LENGE

TAKE THE CHALLENGE

TAKE THE CHALLENGE

TAKE THE CHALLENGE

SERIES



BADMINTON STRING MADE IN JAPAN



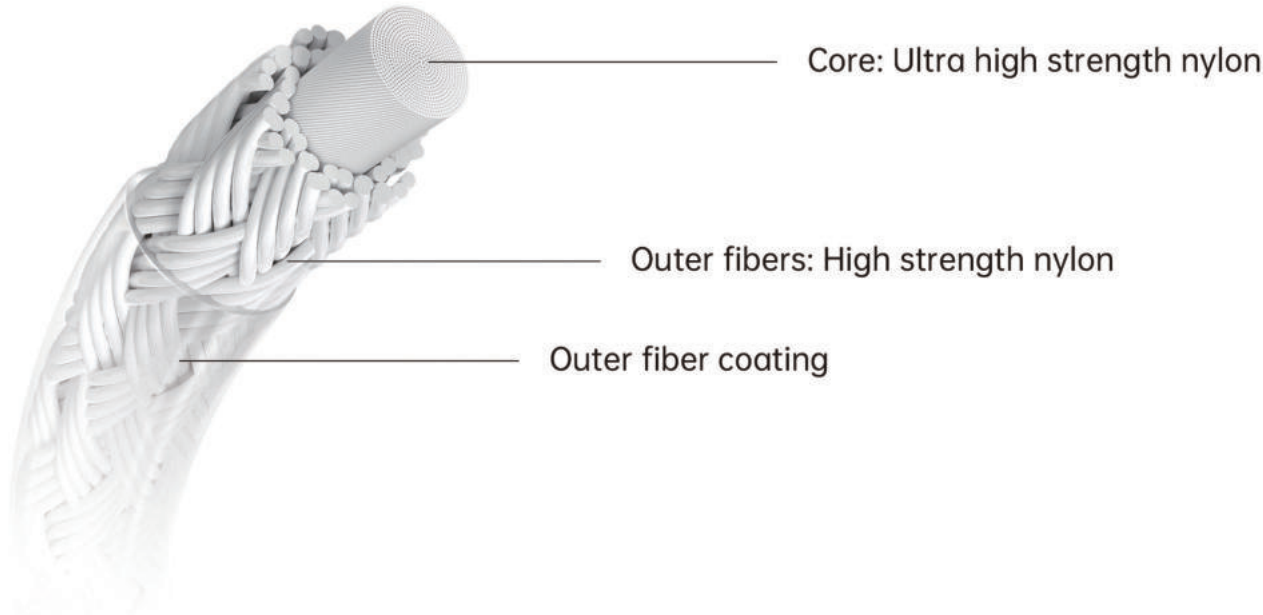

JS - 63 | High Speed; Crisp Sound

JS - 65 | High Repulsion; Accurate Control

GAUGE
0.63mm

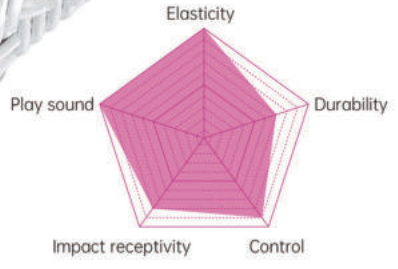
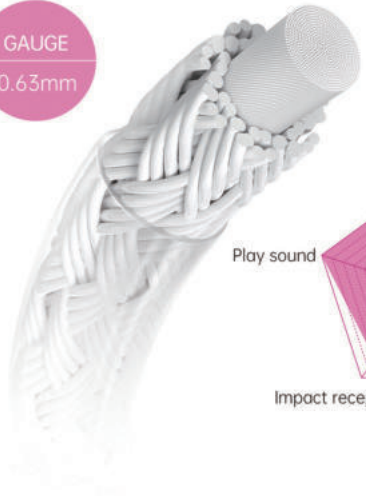

GAUGE
0.65mm

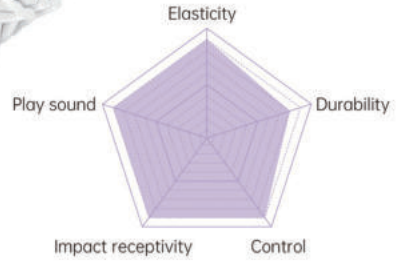

JS - 67 | Good Control; Balanced Performance

JS - 69 | Excellent Durability; Explosive Force

GAUGE
0.67mm



GAUGE
0.69mm

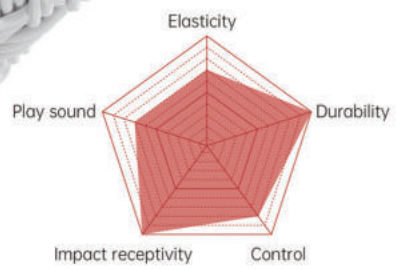



○ White ● Pink ● Blue ● Yellow ● Purple

JS-63 · Crisp Sound

Made in Japan

Material: Ultra high strength nylon(core)+High strength nylon(outer)

Composition: Multifilament+Braiding processing

Size: 0.63mm*10m



○ White ● Pink ● Blue ● Yellow ● Purple

JS-65 · High Elasticity

Made in Japan

Material: Ultra high strength nylon(core)+High strength nylon(outer)

Composition: Multifilament+Braiding processing

Size: 0.65mm*10m



○ White ● Pink ● Blue ● Yellow ● Purple

JS-67 · Excellent Control

Made in Japan

Material: Ultra high strength nylon(core)+High strength nylon(outer)

Composition: Multifilament+Braiding processing

Size: 0.67mm*10m



○ White ● Pink ● Blue ● Yellow ● Purple

JS-69 · High Durability

Made in Japan

Material: Ultra high strength nylon(core)+High strength nylon(outer)

Composition: Multifilament+Braiding processing

Size: 0.69mm*10m



● Black ○ White ● Rose ● Blue ● Light Blue ● Yellow

K65 Durability

Material: High strength nylon multifilament
Size: 0.70mm*10m
Function: Great durability; Wear resistance



○ White ● Rose ● Blue ● Light Blue ● Yellow

K68 Control

Material: High strength nylon multifilament
Size: 0.68mm*10m
Function: High elasticity and durability; Excellent control



○ White ● Pink ● Blue ● Light Blue ● Yellow ● Rose

K70 Elasticity

Material: High strength nylon multifilament
Size: 0.66mm*10m
Function: High elasticity; Crisp sound



○ White ● Rose ● Blue ● Light Blue ● Yellow

KS-58

Material: High strength nylon multifilament
Size: 0.67mm*10m
Function: High elasticity; Crisp sound

TAKE THE CHALLENGE

SHUTTLECOCK *SERIES*

2026
KUMPOO PRODUCT
CATALOG



SHU...OCK

SERIES

TAKE THE CHALLENGE

GAME POINT 99

16 Consecutive Years of BWF Certification

Feather: Natural goose feathers

Cork: Soft wooden cork

Quantity: 12pcs/tube

Application: Advanced tournament

Stability: Class A





KUMPOO RED 1

Feather: Natural goose feathers
Cork: Soft wooden cork
Quantity: 12pcs/tube
Application: Professional tournament
Stability: Class A, Class B



KUMPOO RED 2

Feather: Natural duck feathers
Cork: Compositated cork
Quantity: 12pcs/tube
Application: Professional tournament
Stability: Class A, Class B



KUMPOO RED 3

Feather: Natural duck feathers
Cork: Compositated cork
Quantity: 12pcs/tube
Application: Professional tournament
Stability: Class A, Class B



KUMPOO RED 4

Feather: Natural goose feathers
Cork: Compositated cork
Quantity: 12pcs/tube
Application: Professional tournament
Stability: Class A, Class B



KUMPOO RED 3+

Feather: Natural goose feathers
Cork: Compositated cork
Quantity: 12pcs/tube
Application: Professional tournament
Stability: Class A



K+90

Feather: Natural goose feathers
Cork: Soft wooden cork
Quantity: 12pcs/tube
Application: Professional tournament
Stability: Class A



K+60

Feather: Natural goose feathers
Cork: Compositated cork
Quantity: 12pcs/tube
Application: Professional training
Stability: Class A, Class B



S-107

Feather: Nylon
Cork: Compositated cork
Quantity: 6pcs/tube
Application: Amateur training



S-300II

Feather: Nylon
Cork: Dual-layer cork
Quantity: 6pcs/tube
Application: Amateur training

TAKE THE CHALLENGE

APPAREL *SERIES*

2026
KUMPOO

PRODUCT
CATALOG



ASAP SERIES

THE CHALLENGE

TAKE THE CHALLENGE

TAKE THE CHALLENGE

THE CHALLENGE TAKE THE CHALLENGE

TAKE THE CHALLENGE

KUMPOO AMBASSADOR
Wang Xiaoyu

XiaoYu



K261M-1566 (MEN)
K261W-1567 (WOMEN)



K261M-1158 (MEN)
K261W-1158 (WOMEN)









K261M-1226 (MEN)
K261W-1227 (WOMEN)





Tournament Apparel
K261M-1226 (MEN)

Color: Navy blue/Blue/Green/Pink
Material: 88% Polyester + 12% Spandex
Size: S/M/L/XL/2XL/3XL/4XL
Arrival time: January 2026



Tournament Apparel
K261W-1227 (WOMEN)

Color: Navy blue/Blue/Green/Pink
Material: 88% Polyester + 12% Spandex
Size: S/M/L/XL/2XL/3XL/4XL
Arrival time: January 2026



Tournament Apparel
K261M-1154 (MEN)

Color: Red/Blue/Dark blue/White
Material: 100% Polyester
Size: S/M/L/XL/2XL/3XL/4XL
Arrival time: January 2026



Tournament Apparel
K261U-4222 (UNISEX)

Color: Red/Blue/Dark blue/White
Material: 100% Polyester
Size: S/M/L/XL/2XL/3XL/4XL
Arrival time: January 2026



Tournament Apparel
K261W-1155 (WOMEN)

Color: Red/Blue/Dark blue/White
Material: 100% Polyester
Size: S/M/L/XL/2XL/3XL/4XL
Arrival time: January 2026



Tournament Apparel
K261M-1156 (MEN)

Color: Rose/Dark blue
Material: 88% Polyester + 12% Spandex
Size: S/M/L/XL/2XL/3XL/4XL
Arrival time: January 2026



Tournament Apparel
K261M-4057 (MEN)

Color: Rose/Dark blue
Material: 88% Polyester + 12% Spandex
Size: S/M/L/XL/2XL/3XL/4XL
Arrival time: January 2026



Tournament Apparel
K261W-1158 (WOMEN)

Color: Rose/Dark blue
Material: 88% Polyester + 12% Spandex
Size: S/M/L/XL/2XL/3XL/4XL
Arrival time: January 2026



Tournament Apparel
K261M-1566 (MEN)

Color: Light pink/Dark blue
Material: 100% Polyester
Size: S/M/L/XL/2XL/3XL/4XL
Arrival time: January 2026



Tournament Apparel
K261W-1567 (WOMEN)

Color: Light pink/Dark blue
Material: 100% Polyester
Size: S/M/L/XL/2XL/3XL/4XL
Arrival time: January 2026

K261M-1148 (MEN)
K261W-1149 (WOMEN)





Tournament Apparel
K261M-1148 (MEN)

Color:	Green/Red
Material:	88% Polyester + 12% Spandex
Size:	S/M/L/XL/2XL/3XL/4XL
Arrival time:	January 2026



Tournament Apparel
K261W-1149 (WOMEN)

Color:	Green/Red
Material:	88% Polyester + 12% Spandex
Size:	S/M/L/XL/2XL/3XL/4XL
Arrival time:	January 2026



Tournament Apparel
K261M-1150 (MEN)

Color:	White/Light green/Dark blue
Material:	100% Polyester
Size:	S/M/L/XL/2XL/3XL/4XL
Arrival time:	January 2026



Tournament Apparel
K261W-1151 (WOMEN)

Color:	White/Light green/Dark blue
Material:	100% Polyester
Size:	S/M/L/XL/2XL/3XL/4XL
Arrival time:	January 2026



Tournament Apparel
K261M-1169 (MEN)

Color:	Blue/Pink
Material:	86% Polyester + 14% Spandex
Size:	S/M/L/XL/2XL/3XL/4XL
Arrival time:	January 2026



Tournament Apparel
K261W-1170 (WOMEN)

Color:	Blue/Pink
Material:	86% Polyester + 14% Spandex
Size:	S/M/L/XL/2XL/3XL/4XL
Arrival time:	January 2026



Tournament Apparel
K241M-1038 (MEN)

Color:	White/Red/Blue
Material:	87% Polyester + 13% Spandex
Size:	S/M/L/XL/2XL/3XL/4XL



Tournament Apparel
K241M-4038 (MEN)

Color:	White/Red/Blue
Material:	87% Polyester + 13% Spandex
Size:	S/M/L/XL/2XL/3XL/4XL



Tournament Apparel
K241W-1038 (WOMEN)

Color:	White/Red/Blue
Material:	87% Polyester + 13% Spandex
Size:	S/M/L/XL/2XL/3XL/4XL

K261U-2059 (UNISEX)
K261W-7060 (WOMEN)



7060

2059





Tournament Apparel
K261U-2059 (UNISEX)

Color: White/Red/Navy blue/Black
Material: 95% Polyester + 5% Spandex
Size: S/M/L/XL/2XL/3XL/4XL
Arrival time: January 2026



Tournament Apparel
K261U-2061 (UNISEX)

Color: White/Black/Light green/Dark blue
Material: 90% Nylon + 10% Spandex
Size: S/M/L/XL/2XL/3XL/4XL
Arrival time: January 2026



Tournament Apparel
K261U-2207 (UNISEX)

Color: Light pink/Light yellow/White/Light green
Material: 89% Polyester + 11% Spandex
Size: S/M/L/XL/2XL/3XL
Arrival time: January 2026



Tournament Apparel
K261W-7549 (WOMEN)

Color: White/Red/Black/Dark blue
Material: 100% Polyester
Size: S/M/L/XL/2XL/3XL
Arrival time: January 2026



K261W-7181 (WOMEN)

Color: Green/White/Red/Black
Material: 96.8% Cotton + 3.2% Spandex
Size: S/M/L/XL/2XL/3XL
Arrival time: January 2026



Tournament Apparel
K261W-7060 (WOMEN)

Color: White/Black
Material: 88% Polyester + 12% Spandex
Size: S/M/L/XL/2XL/3XL/4XL
Arrival time: January 2026



Tournament Apparel
K261W-7063 (WOMEN)

Color: Rose/Dark blue/White/Pink
Material: 88% Polyester + 12% Spandex
Size: S/M/L/XL/2XL/3XL/4XL
Arrival time: January 2026

K261M-1731 (MEN)
K261W-1732 (WOMEN)

1732





Tournament Apparel
K261M-1731 (MEN)

Color: Blue/Dark green/Light green
Material: 89.5% Polyester + 10.5% Spandex
Size: S/M/L/XL/2XL/3XL/4XL
Arrival time: January 2026



Tournament Apparel
K261W-1732 (WOMEN)

Color: Blue/Dark green/Light green
Material: 89.5% Polyester + 10.5% Spandex
Size: S/M/L/XL/2XL/3XL/4XL
Arrival time: January 2026



Tournament Apparel
K261W-1730 (WOMEN)

Color: White/Rose/Navy blue/Brown
Material: 88.1% Polyester + 11.9% Spandex
Size: S/M/L/XL/2XL/3XL
Arrival time: January 2026



Tournament Apparel
K261W-1729 (WOMEN)

Color: Black/White/Orange/Pink
Material: 89.5% Polyester + 10.5% Spandex
Size: S/M/L/XL/2XL/3XL/4XL
Arrival time: January 2026



Tournament Apparel
K261W-9727 (WOMEN)

Color: Pink/Navy blue/White/Orange
Material: 84.7% Polyester + 15.3% Spandex
Size: S/M/L/XL/2XL/3XL
Arrival time: January 2026

K251U-5064 (UNISEX)
K251U-6066 (UNISEX)

5064



6066





Training Apparel
K251U-5064 (UNISEX)

Color: Black/White
Material: 90% Polyester + 10% Spandex
Size: S/M/L/XL/2XL/3XL



Training Apparel
K251M-5221 (MEN)

Color: Black
Material: 89% Nylon + 11% Spandex
Size: S/M/L/XL/2XL/3XL



Training Apparel
K261U-1217 (UNISEX)

Color: White/Black
Material: 100% Polyester
Size: S/M/L/XL/2XL/3XL
Arrival time: January 2026



Training Apparel
K261U-4223 (UNISEX)

Color: Green/Blue
Material: 100% Polyester
Size: S/M/L/XL/2XL/3XL
Arrival time: January 2026



Training Apparel
K261U-1224 (UNISEX)

Color: Green/Blue
Material: 100% Polyester
Size: S/M/L/XL/2XL/3XL
Arrival time: January 2026



Training Apparel
K261U-4016 (UNISEX)

Color: Black/Gray
Material: 100% Polyester
Size: S/M/L/XL/2XL/3XL
Arrival time: January 2026



Training Apparel
K261M-3170 (MEN)

Color: White/Black
Material: 77.8% Nylon + 22.2% Spandex
Size: S/M/L/XL/2XL/3XL
Arrival time: January 2026



Training Apparel
K251U-6066 (UNISEX)

Color: White/Black
Material: 90% Polyester + 10% Spandex
Size: S/M/L/XL/2XL/3XL



Training Apparel
K251M-6176 (MEN)

Color: Navy blue
Material: 90.6% Nylon + 9.4% Spandex
Size: S/M/L/XL/2XL/3XL
Arrival time: March 2026

K2610-17/20 (UNISEX)



1720





T-shirts

K261U-1717 (UNISEX)

Color: Light blue/Pink/Dark green/Dark brown/White

Material: 100% Polyester

Size: S/M/L/XL/2XL/3XL

Arrival time: January 2026



T-shirts

K261U-1720 (UNISEX)

Color: Dark blue/Red/Green/Brown/Off-white

Material: 100% Polyester

Size: S/M/L/XL/2XL/3XL

Arrival time: January 2026



T-shirts

K261U-1718 (UNISEX)

Color: Black/White/Pink/Green

Material: 100% Polyester

Size: S/M/L/XL/2XL/3XL

Arrival time: January 2026



T-shirts

K261M-1171 (MEN)

Color: White/Black

Material: 100% Cotton

Size: S/M/L/XL/2XL/3XL

Arrival time: January 2026



T-shirts

K261U-1024 (UNISEX)

Color: Gray/Black

Material: 100% Polyester

Size: S/M/L/XL/2XL/3XL

Arrival time: January 2026



T-shirts

K261M-1240 (MEN)

Color: White/Green/Black

Material: 74.2% Cotton + 25.8% Polyester

Size: S/M/L/XL/2XL/3XL

Arrival time: January 2026

K261W-1558 (WOMEN)



1558





T-shirts

K261M-1173 (MEN)

Color:	White/Black
Material:	100% Cotton
Size:	S/M/L/XL/2XL/3XL
Arrival time:	January 2026



Training Apparel

K261W-1234 (WOMEN)

Color:	Blue/White/Black
Material:	83.8% Nylon + 16.2% Spandex
Size:	S/M/L/XL/2XL/3XL
Arrival time:	March 2026



Training Apparel

K261W-1558 (WOMEN)

Color:	Blue/Navy blue/Purple
Material:	89.9% Polyester + 10.1% Spandex
Size:	S/M/L/XL/2XL/3XL
Arrival time:	March 2026



Training Apparel

K261W-1140 (WOMEN)

Color:	Gray/Black
Material:	46.2% Cotton + 44.9% Viscose + 8.9% Spandex
Size:	S/M/L/XL/2XL/3XL
Arrival time:	January 2026



Training Apparel

K261W-4122 (WOMEN)

Color:	Gray/Dark gray
Material:	46.2% Viscose + 44.9% Cotton + 8.9% Spandex
Size:	S/M/L/XL/2XL/3XL
Arrival time:	January 2026



Training Apparel

K261W-7182 (WOMEN)

Color:	Dark red/White/Black/Blue
Material:	96.8% Cotton + 3.2% Spandex
Size:	S/M/L/XL/2XL/3XL
Arrival time:	March 2026



Training Apparel

K251W-7225 (WOMEN)

Color:	Gray/Black
Material:	46.2% Viscose + 44.9% Cotton + 8.9% Spandex
Size:	S/M/L/XL/2XL



Training Apparel

K261W-7183 (WOMEN)

Color:	Black/White
Material:	88.6% Nylon + 11.4% Spandex
Size:	S/M/L/XL/2XL/3XL
Arrival time:	March 2026



Training Apparel

K261W-7226 (WOMEN)

Color:	White/Black
Material:	90.5% Polyester + 9.5% Spandex
Size:	S/M/L/XL/2XL/3XL
Arrival time:	January 2026

Training Apparel

K251M-5224

Material: Outer fabric: 100% Polyester
 Lining fabric: 100% Polyester
 Filling: 85% Down content

Size: M/L/XL/2XL/3XL



Navy blue

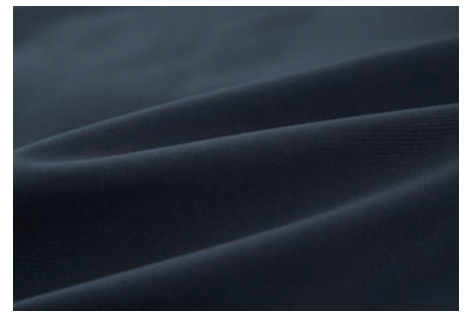

Product features:

- Windproof brim features an adjustable drawstring, a double-headed zipper at the front, and adjustable cuffs with Velcro.
- Zippers are added on both sides of the hem for better adjustment of the fit.
- The back has a heat retention function, and the long design covers the waist and hips, enhancing the warmth range.
- Outer fabric is waterproof and anti-static, while lining fabric is anti-static, ensuring dryness in rainy and snowy weather.
- Loose design accommodates various body types, making it convenient for sports.

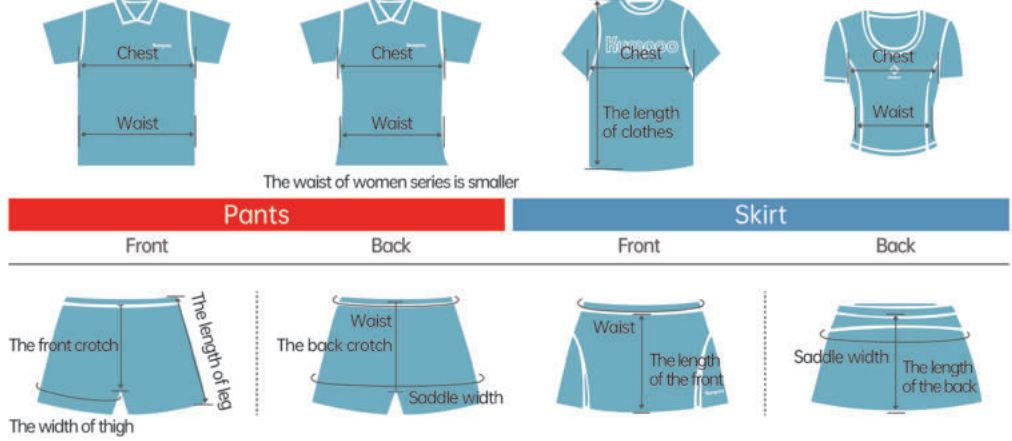
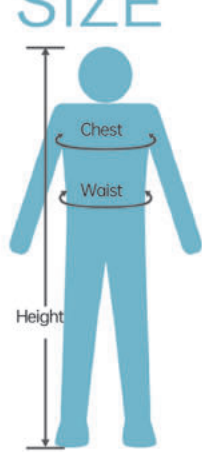

The waist of women series is smaller

Size	Specification	Actual measurement size		Height(CM)	Weight(KG)
		Clothes length	Chest		
S	165/84A	67	96	160-165	45-55
M	170/88A	69	101	165-170	55-65
L	175/92A	71	106	170-175	65-75
XL	180/96A	73	111	175-180	75-83
2XL	185/100A	75	116	180-185	83-90
3XL	190/104A	77	121	185-190	90-98
4XL	195/108A	79	126	190-195	98-105

Size	Specification	Actual measurement size		Height(CM)	Weight(KG)
		Clothes length	Chest		
S	155/80A	58	84	150-155	40-45
M	160/84A	60	89	155-160	45-50
L	165/88A	62	94	160-165	50-55
XL	170/92A	64	99	165-170	55-60
2XL	175/96A	66	104	170-175	60-65
3XL	180/100A	68	109	175-180	65-70
4XL	185/104A	70	114	180-185	70-75

Size	Specification	Actual measurement size		Height(CM)	Weight(KG)
		Clothes length	Chest		
S	165/84A	70	104	160-165	45-55
M	170/88A	72	108	165-170	55-65
L	175/92A	74	112	170-175	65-75
XL	180/96A	76	116	175-180	75-83
2XL	185/100A	78	120	180-185	83-90
3XL	190/104A	80	124	185-190	90-98

Size	Specification	Actual measurement size		Height(CM)	Weight(KG)
		Chest	Waist		
S	155/80A	80	67	155-160	30-40
M	160/84A	84	72	160-165	35-45
L	165/88A	88	75	165-170	45-53
XL	170/92A	92	79	170-175	53-60
2XL	175/96A	96	83	175-180	60-65
3XL	180/100A	100	87	180-185	65-70

Size	Specification	Actual measurement size				Reference value	
		Pant length	1/2 Waist	Hipline	Hem width	Weight(KG)	Waistband size
XS	160/68A	39	29	94	26	40-45	25-26
S	165/72A	40.5	31.5	99	27	45-55	27-28
M	170/76A	42	34	104	28	55-65	29-30
L	175/80A	43.5	36.5	109	29	65-75	31
XL	180/84A	45	39	114	30	75-83	32
2XL	185/88A	46.5	41.5	119	31	83-90	33-34
3XL	190/92A	48	44	124	32	90-98	35-36
4XL	195/96A	49.5	46.5	129	33	98-105	37-38

Size	Specification	Actual measurement size			Reference value	
		Skirt length	1/2 Waist	Hipline	Weight(KG)	Waistband size
S	155/66A	32	62	74	40-45	25
M	160/70A	33	66	78	45-50	26
L	165/74A	34	70	82	50-55	27
XL	170/78A	35	74	86	55-60	28
2XL	175/82A	36	78	90	60-65	29
3XL	180/86A	37	82	94	65-70	30-31

Size	Specification	Actual measurement size		Height(CM)	Weight(KG)
		Clothes length	Chest		
XS	160/80A	64	91	155-160	40-45
S	165/84A	66	96	160-165	45-55
M	170/88A	68	101	165-170	55-65
L	175/92A	70	106	170-175	65-75
XL	180/96A	72	111	175-180	75-83
2XL	185/100A	74	116	180-185	83-90
3XL	190/104A	76	121	185-190	90-98
4XL	195/108A	78	126	190-195	98-105

TAKE THE CHALLENGE

JUNIOR SERIES

2026
KUMPOO

PRODUCT
CATALOG



JUNIOR SERIES



TAKE THE CHALLENGE

TAKE THE CHALLENGE

TAKE THE CHALLENGE

TAKE THE CHALLENGE

TAKE THE CHALLENGE

TAKE THE CHALLENGE

TAKE THE CHALLENGE

TAKE THE CHALLENGE

TAKE THE CHALLENGE

TAKE THE CHALLENGE

TAKE THE CHALLENGE

TAKE THE CHALLENGE

TAKE THE CHALLENGE

TAKE THE CHALLENGE



KH-JG826S



KH-JG826S

KUMPOO

KH-JG826S

KUMPOO

KH-JG826S

KUMPOO



A

KH-JG826S (Junior)

Color: A-Pink/green; B-Green/orange; C-White/red/black; D-White
Upper: TPU+Mesh+Flyknit+Fitgo
Insole and lining: Fabric+EVA
Sole: Natural rubber+MD+TPU+ACF
Size: 31-34#



B



C



D

Arrival time: January 2026

Remark: With shoe bag



A



B



C

KH-J08 (Junior)

Color: A-White/light gray; B-White/blue; C-White/green
Upper: TPU+Mesh
Insole and lining: Fabric+EVA
Sole: Natural rubber+MD+Carbon plate
Size: 31-37#

Remark: With shoe bag



A



B

KHS-J10 (Junior)

Color: A-White/green; B-White/blue
Upper: PU+Mesh+Fitgo
Insole and lining: Fabric+EVA
Sole: Natural rubber+MD+Carbon plate
Size: 31-37#

Remark: With shoe bag



A



B



C

KHS-J20 (Junior)

Color: A-White/gray; B-White/purple; C-White/blue
Upper: PU+Mesh
Insole and lining: Fabric+EVA
Sole: Natural rubber+MD+Carbon plate
Size: 31-37#

Remark: With shoe bag



3

2

2

2

XINJING



Tournament Apparel
K261K-1197 (KIDS)

Color: Blue/Green
 Material: 92.7% Polyester + 7.3% Spandex
 Size: 110/120/130/140/150/160
 Arrival time: January 2026



Tournament Apparel
K253K-1118 (KIDS)

Color: Pink/Green
 Material: 100% Polyester
 Size: 110/120/130/140/150/160



Tournament Apparel
K253M-1116 (MEN)

Color: Pink/Green
 Material: 100% Polyester
 Size: S/M/L/XL/2XL/3XL/4XL



Tournament Apparel
K253W-1117 (WOMEN)

Color: Pink/Green
 Material: 100% Polyester
 Size: S/M/L/XL/2XL/3XL/4XL



Tournament Apparel
K253K-1147 (KIDS)

Color: Blue/Green/Pink
 Material: 100% Polyester
 Size: 110/120/130/140/150/160



Tournament Apparel
K253M-1987 (MEN)

Color: Blue/Green/Pink
 Material: 100% Polyester
 Size: S/M/L/XL/2XL/3XL/4XL



Tournament Apparel
K253W-1988 (WOMEN)

Color: Blue/Green/Pink
 Material: 100% Polyester
 Size: S/M/L/XL/2XL/3XL/4XL



Tournament Apparel
K253K-2004 (KIDS)

Color: Navy blue/Green
 Material: 95% Polyester + 5% Spandex
 Size: 110/120/130/140/150/160



Tournament Apparel
K253U-2002 (UNISEX)

Color: Navy blue/Green
 Material: 95% Polyester + 5% Spandex
 Size: S/M/L/XL/2XL/3XL/4XL





Tournament Apparel

K253W-7999 (WOMEN)

Color:	White/Dark blue/Green
Outer fabric:	84.8% Polyester + 15.2% Spandex
Lining fabric:	92.6% Polyester + 7.4% Spandex
Size:	S/M/L/XL/2XL/3XL/4XL



Tournament Apparel

K261K-7227 (KIDS)

Color:	Purple/Blue/Black
Material:	90.5% Polyester + 9.5% Spandex
Size:	110/120/130/140/150/160
Arrival time:	January 2026



Tournament Apparel

K253K-2116 (KIDS)

Color:	Black
Material:	95% Polyester + 5% Spandex
Size:	110/120/130/140/150/160



Tournament Apparel

K253U-2117 (UNISEX)

Color:	Black
Material:	95% Polyester + 5% Spandex
Size:	S/M/L/XL/2XL/3XL/4XL



Tournament Apparel

K261K-2208 (KIDS)

Color:	Light pink/Light yellow/White/Light green
Material:	89% Polyester + 11% Spandex
Size:	110/120/130/140/150/160
Arrival time:	January 2026





T-shirts

K261K-1205 (KIDS)

Color:	Yellow/Purple/Pink
Material:	100% Polyester
Size:	110/120/130/140/150/160
Arrival time:	January 2026



T-shirts

K261U-1204 (UNISEX)

Color:	Yellow/Purple/Pink
Material:	100% Polyester
Size:	S/M/L/XL/2XL/3XL/4XL
Arrival time:	January 2026



T-shirts

KWX-3002K (KIDS)

Color:	Purple/Black
Material:	100% Polyester
Size:	110/120/130/140/150/160



T-shirts

KWX-3002U (UNISEX)

Color:	Purple/Black
Material:	100% Polyester
Size:	S/M/L/XL/2XL/3XL/4XL



T-shirts

K261K-1186 (KIDS)

Color:	White/Pink/Purple
Material:	94% Cotton + 6% Spandex
Size:	110/120/130/140/150/160
Arrival time:	March 2026



Training Apparel

K253K-5004 (KIDS)

Color:	Green/Blue
Material:	90% Polyester + 10% Spandex
Size:	130/140/150/160



Training Apparel

K253U-5003 (UNISEX)

Color:	Green/Blue
Material:	90% Polyester + 10% Spandex
Size:	S/M/L/XL/2XL/3XL/4XL



Training Apparel

K253K-3999 (KIDS)

Color:	Navy blue/Green
Material:	100% Cotton
Size:	120/130/140/150/160



Training Apparel

K253U-3998 (UNISEX)

Color:	Navy blue/Green
Material:	100% Cotton
Size:	XS/S/M/L/XL/2XL/3XL/4XL



KB-672

Kid's Backpack

Color: A-Orange/off-white;
B-Green/off-white; C-Purple

Material: Fabric

Size: 42*30*16cm

Arrival time May 2026



A



B



C

KB-523

Kid's Backpack

Color: A-Orange/blue; B-Green/purple

Material: Fabric

Size: 29*16*40cm



A



B

KB-671

Kid's Backpack

Color: A-Blue; B-Purple

Material: Fabric

Size: 41*30*16cm

Arrival time January 2026



A



B



Flannelette Bag

520A (S)

Frame material: Carbon fiber+Resin
 Shaft material: Carbon fiber+Resin
 Weight/Grip: 4U/G5
 Tension: ≤24LBS
 Color: White/red; White/yellow

Suitable for beginners.



Flannelette Bag

520B (S)

Frame material: Carbon fiber+Resin
 Shaft material: Carbon fiber+Resin
 Weight/Grip: 4U/G5
 Tension: ≤24LBS
 Color: Black/purple; Black/blue

Suitable for beginners.



Bag

E30

Frame material: 6061 Aluminum
 Shaft material: Carbon fiber+Resin
 Weight/Grip: 3U/G5
 Tension: ≤24LBS
 Color: Light purple; Light green;
 Light blue; Light pink

The unique square cross-section design creates a stable frame structure, enhancing shot accuracy, making it an excellent choice for beginners.



Bag

POPPING CANDY

Frame material: Carbon fiber+Resin
 Shaft material: Carbon fiber+Resin
 Weight/Grip: 6U/G6
 Tension: ≤24LBS
 Color: Yellow; Blue

580mm length and lightweight experience, specially designed for children.



Flannelette Bag

NEW

LT-001

Arrival time: May 2026

Frame material: Aluminum alloy
 Shaft material: Ferroalloy
 Tension: ≤22LBS
 Color: Blue; Pink

580mm length and lightweight experience, specially designed for children.

25 YEARS OF CHALLENGE

2001-2026

25TH ANNIVERSARY SERIES



25 YEARS OF CHALLENGE

25TH ANNIVERSARY LIMITED EDITION



25 years of KUMPOO — built on professionalism and strength.
 At 25, we continue to embody youth and courage.
 We believe that wherever the wind rises, a new challenge begins.



25
Kumpoo
5

25TH ANNIVERSARY LIMITED EDITION

TAKE THE CHALLENGE

25 YEARS OF CHALLENGE



Racket_25th Anniversary Series

RIDE THE WIND S.25th (6U)

Arrival time: January 2026

Frame material: High strength carbon fiber

Shaft material: High strength carbon fiber

Weight/Grip: 6U/G6

Tension: ≤30LBS

Color: Pink



Gift Box

Riding the Wind for 25 Years, a New Journey Begins. With lightweight performance at its core, the streamlined racket frame is adorned with spring-inspired colors—embodying the agility and grace of “when the wind rises,” while reflecting the solid foundation built through “winds long endured.”



Patent No.: ZL200820201080.7

2300 DAREN.25th Racket_25th Anniversary Series

Arrival time: January 2026

Frame material: High strength carbon fiber

Shaft material: High strength carbon fiber

Weight/Grip: 4U/G5

Tension: ≤35LBS

Color: Green



Gift Box

Green and pink intertwine, embodying 25 years of composure and vitality. The HEXAGON shaft drives precise strikes, while the poplar wood handle absorbs vibration. Beneath its minimalist lines lies an unyielding spirit of forward momentum and relentless drive.

Gift Set includes:
Racket*1
Flannelette bag*1
Grip: KG-17.25th*1

CHALLENGE

EMERGENCE

PROGRESS



2 /
Kumpoo
5 \



TAKE THE CHALLENGE

25 YEARS OF CHALLENGE

Shoes_25th Anniversary Series

KH-G828.25th



Color: Green/Pink

Upper: PU+TPU+Mesh

Lining: Fabric+EVA

Sole: Rubber+Supercritical midsole+TPU+Carbon plate+ACF

Size: 35-45#

Arrival time January 2026



Remark: With a professional shoe bag and a shoe box

Shoes_25th Anniversary Series

KH-D72PRO.25th



Color: White/Pink

Upper: TPU+PU+Mesh

Lining: Fabric+EVA

Sole: Rubber+LEOBOOM midsole+TPU+Carbon plate

Size: 35-45#

Arrival time January 2026



Remark: With a professional shoe bag and a shoe box





A-Green



B-Pink

Tournament Apparel_25th Anniversary Series

K261M-1531.25th (MEN)

Material: 100% Polyester

Size: S/M/L/XL/2XL/3XL/4XL

Arrival time: January 2026



A-Green



B-Pink

Tournament Apparel_25th Anniversary Series

K261W-1532.25th (WOMEN)

Material: 100% Polyester

Size: S/M/L/XL/2XL/3XL/4XL

Arrival time: January 2026



A-Green



B-White

Training Apparel_25th Anniversary Series

K261U-1528.25th (UNISEX)

Material: 100% Cotton

Size: S/M/L/XL/2XL/3XL/4XL

Arrival time: January 2026



A-Green

B-White

Training Apparel_25th Anniversary Series

K261U-5545.25th (UNISEX)

Shell: 90.6% Nylon+9.4% Spandex

Lining: 100% Polyester

Size: S/M/L/XL/2XL/3XL/4XL

Arrival time: January 2026



White

Tournament Apparel_25th Anniversary Series

K261U-2540.25th (UNISEX)

Material: 89.4% Nylon+10.6% Spandex

Size: S/M/L/XL/2XL/3XL/4XL

Arrival time: January 2026



White

Tournament Apparel_25th Anniversary Series

K261W-7542.25th (WOMEN)

Material: 90.2% Nylon+9.8% Spandex

Size: S/M/L/XL/2XL/3XL/4XL

Arrival time: January 2026



White

Training Apparel_25th Anniversary Series

K261U-6546.25th (UNISEX)

Material: 89.4% Nylon+10.6% Spandex

Size: S/M/L/XL/2XL/3XL/4XL

Arrival time: January 2026

CHALLENGE

EMERGENCE

PROGRESS



TAKE THE CHALLENGE

25 YEARS OF CHALLENGE



Front



Back

Square bag_25th Anniversary Series

KB-566.25th

Color: White/green

Material: Synthetic leather+Fabric

Size: 70*30*16cm

Arrival time: January 2026



Front



Back

Backpack_25th Anniversary Series

KB-5212.25th

Color: White/pink

Material: Synthetic leather+Fabric

Size: 30*16*45cm

Arrival time: January 2026



Pink/Green

Grip_25th Anniversary Series

KG-17.25th

Material: Polyurethane + Non-woven fabric

Size: 1100*25mm

Arrival time: January 2026



A-Green



B-Pink

Socks_25th Anniversary Series

KSO-507.25th

Material: 87% cotton+11% polyester fiber+2% spandex

Size: 24-26

Arrival time: January 2026



A-Green



B-Pink

Wristband_25th Anniversary Series

KWT-504.25th

Material: 80% cotton+18% polyester fiber+2% spandex

Size: 8*8cm

Arrival time: January 2026



A-Green



B-Pink

Headband_25th Anniversary Series

KHD-5010.25th

Material: 74% cotton+24% polyester fiber+2% spandex

Size: 18*5cm

Arrival time: January 2026



A-Green



B-Pink

Towel_25th Anniversary Series

KT-517.25th

Material: 100% Microfiber

Size: 40*90cm

Arrival time: January 2026

CHALLENGE

EMERGENCE

PROGRESS



TAKE THE CHALLENGE

25 YEARS OF CHALLENGE

TAKE THE CHALLENGE

BAG SERIES

2026
KUMPOO

PRODUCT
CATALOG

BAG SERIES



TAKE THE CHALLENGE

TAKE THE CHALLENGE

TAKE THE CHALLENGE

TAKE THE CHALLENGE

TAKE THE CHALLENGE

TAKE THE CHALLENGE

TAKE THE CHALLENGE

TAKE THE CHALLENGE



KB-631

Professional Bag-Holds 3 Rackets

Color: A-Purple/white; B-Black/white

Material: Synthetic leather+Fabric

Size: 70*11*27cm

Arrival time: January 2026



A



B



Product features :

- ◆ Made of PU with toothpick texture, soft, waterproof and wear-resistant.
- ◆ Lightweight and portable, with multifunctional pockets and dual carry options.
- ◆ Equipped with multifunctional slip pockets inside for organized storage.



KB-632

Ita Series-Square Bag

Color: A-White; B-Yellow/white; C-Blue/white

Material: Fabric

Size: 48*27*18cm

Arrival time: May 2026



A



B



C



Product features :

- ◆ Made of polyester composite fabric, the bag is light and soft, yet strong and wrinkle-resistant.
- ◆ Front attachment loop for display of various accessories or decorations.
- ◆ The front pockets features a transparent PVC cover and one of them comes with a display board, allowing personalized decoration with badges, keychains, or small plush toys.
- ◆ Functional compartments such as a half-open racket section and a dedicated shoe compartment provide refined protection for badminton equipment.
- ◆ Offers strong storage capacity, with a inner zip pocket in the main compartment, mesh side pockets on both sides, plus a back zip pocket.
- ◆ Equipped with both long and short shoulder straps for single-shoulder or crossbody carry, this bag combines the features of an ita bag and a badminton bag to suit various usage scenarios.



KB-634

Square Bag-Holds 3 Rackets

Color: A-Blue/white; B-Black/off white

Material: Fabric

Size: 72*32*13cm

Arrival time: January 2026



A



B



Product features :

- ◆ Made of 900D Oxford fabric as the main material, this bag features a minimalist design with a prominent kumpoo logo.
- ◆ Features a multi-functional front pocket and a D-ring for additional attachment, providing strong storage capability.
- ◆ Equipped with a dedicated shoe compartment, an interior racket divider for protection, and additional slip pockets for organized storage.
- ◆ Carried over one shoulder, it is slimmer and lighter than standard box-shaped bags for easier portability.



KB-661

Professional Bag-Holds 6 Rackets

Color: A-Black/white; B-Khaki/white

Material: Fabric

Size: 59*22*31cm

Arrival time: January 2026



A



B



Product features :

- ◆ Made from high-quality matte 600D plain-weave fabric, this specially treated material not only gives the bag a refined, understated look, but also offers excellent abrasion and tear resistance.
- ◆ Separate racket compartments for racket protection. ◆ Separate shoe compartment, clean and convenient.
- ◆ The large main compartment offers ample space to accommodate all your essentials — from spare clothing to personal items — keeping everything neatly organized and easily accessible.
- ◆ A front pocket with magnetic closure and two pockets with zipper closure.



KB-662

Square Bag-Holds 6 Rackets

Color: A-Black/white; B-Purple/white; C-Blue/white

Material: Synthetic leather+Fabric

Size: 73*20*32cm

Arrival time: May 2026



A



B



C



Product features :

- ◆ Made of synthetic leather, waterproof, wear-resistant, and easy to clean.
- ◆ Separate aluminum foil insulated racket compartment and independent shoe section, providing refined protection for badminton equipment.
- ◆ The main compartment includes slip and zip pockets, while the front features a large-capacity zip pocket and additional zip pockets on both the front and back panels, offering enhanced storage functionality.
- ◆ Front attachment loop for display of various accessories or decorations.
- ◆ Equipped with dual shoulder straps for versatile carrying options — can be worn on the back or carried by hand.





A



B



C

KB-663

Square Bag-Holds 6 Rackets

Color: A-Silver/grey; B-Green/white; C-Khaki/white

Material: Synthetic leather+Fabric

Size: 73*20*32cm

Arrival time: January 2026



Product features :

- ◆ Made of matte PU material with a skin-friendly, jelly-like texture, water-repellent and easy to maintain.
- ◆ Separate aluminum foil insulated racket compartment and independent shoe section, providing refined protection for badminton equipment.
- ◆ With multiple storage compartments, including a front flap pocket, a front zip pocket, and an additional zip slip pocket.
- ◆ Front attachment loop for display of various accessories or decorations.
- ◆ Equipped with dual shoulder straps for versatile carrying options — can be worn on the back or carried by hand.



KB-691

Square Bag-Holds 9 Rackets

Color: A-Khaki/white; B-Red/white

Material: Synthetic leather+Fabric

Size: 75*30*33cm

Arrival time: January 2026



A



B



Product features :

- ◆ Crafted from a combination of cross-grain and smooth leather, waterproof, wear-resistant, and easy to clean.
- ◆ Large capacity with a 9-racket design, featuring multiple compartments including a racket section, dedicated shoe compartment, and clothing compartment for organized storage.
- ◆ Equipped with dual shoulder straps for versatile carrying options — can be worn on the back or carried by hand.
- ◆ Aluminum foil insulated racket compartment with professional-grade foil for effective heat insulation and racket protection.
- ◆ Functional front and back zip pockets enhance storage capacity.

KB-664

Profesional Series-Holds 6 rackets

Color: A-Khaki/white; B-Red/white; C-Navy blue/white

Material: Fabric

Size: 73*22*31cm

Arrival time: January 2026



A



B



C



Product features :

- ◆ This bag features an asymmetric design paired with a prominent large logo for a bold yet minimal aesthetic.
- ◆ Equipped with a large front pocket for easy access to your daily essentials.
- ◆ A front mesh bottle pocket keeps water bottle within easy reach at all times.
- ◆ A detachable shoe section is included in the main compartment for organized storage.
- ◆ With a separate racket compartment providing effective protection for rackets.

KB-665

Professional Series-Holds 6 rackets

Color: Black/orange

Material: Synthetic leather+Fabric

Size: 75*30*33cm

Arrival time: May 2026



Product features :

- ◆ This bag is inspired by the design elements of the Spike X racket.
- ◆ It features separate compartments for rackets and shoes, offering well-organized storage.
- ◆ Additional front and back zip pockets further enhance its storage functionality.



KB-621

Ita Series-Backpack

Color: A-Yellow/white; B-White; C-Blue/white

Material: Fabric

Size: 45*30*18cm

Arrival time: May 2026



A



B



C



Product features :

- ◆ Made of polyester composite fabric, the bag is light and soft, yet strong and wrinkle-resistant.
- ◆ Front adjustable attachment loop for display of various accessories or decorations.
- ◆ The front pockets features a transparent PVC cover and one of them comes with a display board, allowing personalized decoration with badges, keychains, or small plush toys.
- ◆ Separate compartments for shoes and rackets, providing refined protection for badminton equipment.
- ◆ Offers strong storage capacity, with inner slip and zip pockets in the main compartment, plus mesh side pockets on both sides.
- ◆ A combination of an ita bag and a badminton bag for various usage scenarios.



KB-623

DuPont Tyvek Series-Backpack

Color: A-Silver; B-Green/white; C-Pink/white

Material: DuPont Tyvek fabric

Size: 41*30*16cm

Arrival time: May 2026



A



B



C



Product features :

- ◆ Made from eco-friendly DuPont Tyvek material, the bag embodies a sustainable design concept and promotes green living.
- ◆ The material is water-resistant, durable, and tear-resistant, ensuring long-lasting use.
- ◆ Functional compartments, including a dedicated racket section and professional shoe compartment, provide refined protection for badminton gear.
- ◆ A zippered pocket on the flap offers convenient storage for small items, while side slip pockets are perfect for carrying shuttle tubes, water bottles, or umbrellas.



A



B



C

KB-622

Professional Series-Backpack

Color: A-Khaki/white; B-Red/white; C-Navy blue/white

Material: Fabric

Size: 29*16*47cm

Arrival time: January 2026



Product features :

- ◆ It features strong storage capacity, with two front zip pockets, two mesh side pockets, as well as an adjustable bungee cord for hanging items.
- ◆ A detachable shoe section is included in the main compartment for organized storage.
- ◆ With a separate racket compartment providing effective protection for rackets.
- ◆ Two side mesh pockets for carrying shuttlecock tubes, water bottles, and other items.



A



B



C

KB-624

Outdoors Series-Backpack

Color: A-Grey/white; B-Black/white; C-Green/yellow/white

Material: Synthetic leather+Fabric

Size: 45*30*18cm

Arrival time: January 2026



Product features :

- ◆ Made with PU-coated material, abrasion-resistant, scratch-resistant, and water-repellent.
- ◆ With a separate racket compartment providing effective protection for rackets.
- ◆ The front zip sub-compartment, zip pocket, side mesh pouch, and mesh storage pocket provide organized storage for different needs.
- ◆ The front panel is equipped with an adjustable bungee cord and a quick-release buckle, while the bottom features an external strap system and selected areas are enhanced with reflective material.
- ◆ This model is designed as an outdoor bag with racket-carrying functionality, offering multiple storage options and strong overall functionality.





A



B



C

KB-611

Ita Series-Tote Bag

Color: A-Blue/white; B-Yellow/white; C-White

Material: Fabric

Size: 44*28*13cm

Arrival time: May 2026



Product features :

- ◆ Made of polyester composite fabric, the bag is light and soft, yet strong and wrinkle-resistant.
- ◆ Side attachment loop for display of various accessories or decorations.
- ◆ The front pocket features a transparent PVC cover and comes with a display board, allowing personalized decoration with badges, keychains, or small plush toys.
- ◆ Offers strong storage capacity, with inner slip and zip pockets in the main compartment, a mesh side pocket, plus a back zip pocket.
- ◆ Single-shoulder carry design, suitable for daily outings, leisure, and commuting in various occasions.





A



B



C

KB-612

DuPont Tyvek Series-Tote Bag

Color: A-Silver; B-Green/white; C-Pink/white

Material: DuPont Tyvek fabric

Size: 44*34*15cm

Arrival time: May 2026



Product features :

- ◆ Made from eco-friendly DuPont Tyvek material, the bag embodies a sustainable design concept and promotes green living.
- ◆ The material is water-resistant, durable, and tear-resistant, ensuring long-lasting use.
- ◆ Functional storage compartments, including a back zip pocket, an inner slip pocket and a side pocket on both sides.
- ◆ With a D-ring for hanging decorations or other items. ◆ Dedicated shoe compartment, a highlight of the tote bag.
- ◆ Hand-carry or shoulder-carry design for versatile use.





A



B



C

KB-613

DuPont Tyvek Series-Crossbody Bag

Color: A-Silver; B-Green/white; C-Pink/white

Material: DuPont Tyvek fabric

Size: 32*30*11cm

Arrival time: May 2026



Product features :

- ◆ Made from eco-friendly DuPont Tyvek material, the bag embodies a sustainable design concept and promotes green living.
- ◆ The material is water-resistant, durable, and tear-resistant, ensuring long-lasting use.
- ◆ Magnetic closure for easy access. ◆ Can be carried by hand or worn crossbody.
- ◆ Inner slip pocket for organized storage.

TAKE THE CHALLENGE

ACCESSORY *SERIES*

2026
KUMPOO

PRODUCT
CATALOG





With floral fragrance

KG-13 (3pcs/pack)

Material: Polyurethane + Non-woven fabric

Size: 1200*25mm*0.65mm

Color: White; Black; Pink; Purple; Blue; Green



Towel grip

KG-12 (1pcs/pack)

Material: Cotton

Size: 750mm*30mm*2.4mm

Color: Purple; Blue; Pink; Yellow; Green



Towel grip

KG-12 (10m/coil)

Material: Cotton

Size: 10m*30mm*2.4mm

Color: Purple; Blue; Pink; Yellow; Green



Sticky grip

KG-30 (2pcs/pack)

Material: Polyurethane + Non-woven fabric

Size: 25*1100*0.7mm

Color: Pink; Black; Dark blue; Green; Dark purple; White; Yellow; Fluorescent yellow; Light blue; Light purple; Mint blue; Orange

Function: Slip-proof; Sticky; Sweat-absorbent



Sticky grip
KG-30 (9pcs/pack)

Material: Polyurethane + Non-woven fabric
 Size: 25*1100*0.7mm
 Color: Red; Yellow; Blue; Green; Black; White; Purple; Pink; Mint blue
 Function: Slip-proof; Sticky; Sweat-absorbent



Barrel grip
KG-301 (60pcs/barrel)

Material: Polyurethane + Cotton
 Size: 25*1200*0.6mm
 Color: White; Black; Purple; Green; Fluorescent yellow; Pink
 Function: Comfortable; Slip-proof



Barrel grip
KG-302 (60pcs/barrel)

Material: Polyurethane + Microfiber
 Size: 25*1200*0.75mm
 Color: Red; Black; Green; Purple; Pink; Blue; White; Orange; Yellow; Mixed
 Function: Soft; Comfortable; Durable



A-Blue/white

B-Purple/white

C-Pink/white

Crew Socks

KSO-601W

Material: 82.8% cotton + 12.1% polyester fiber + 2.7% other fibers + 1.5% diene elastic fiber + 0.9% spandex

Size: 18-22

Feature: Breathable mesh on the instep; Arch elastic band; Thickened toe and heel; Scalloped floral cuff

Arrival time: January 2026



A-White

B-Blue

C-Pink

Crew Socks

KSO-602W

Material: 82.8% cotton + 12.1% polyester fiber + 2.7% other fibers + 1.5% diene elastic fiber + 0.9% spandex

Size: 22-24

Feature: Breathable mesh on the instep; Arch elastic band; Thickened toe and heel

Arrival time: January 2026



A-Black

B-Green

Crew Socks

KSO-603

Material: 87% cotton + 11% polyester fiber + 2% spandex

Size: 24-26

Feature: Arch elastic band; Thickened toe and heel

Arrival time: January 2026



A-Pink

B-Purple

Crew Socks

KSO-604

Material: 87% cotton + 11% polyester fiber + 2% spandex

Size: 24-26

Feature: Breathable mesh on the instep; Arch elastic band; Thickened toe and heel

Arrival time: January 2026



A-Green B-Purple C-Yellow D-Blue

Crew Socks
KSO-605J

Material: 82% cotton + 16% polyester fiber + 2% spandex
Size: 18-22
Feature: Arch elastic band; Thickened toe and heel
Arrival time: January 2026



A-Orange/black B-Red/white C-Blue/white D-Purple/pink

Crew Socks
KSO-606

Material: 82% cotton + 16% polyester fiber + 2% spandex
Size: 24-26
Feature: Thickened toe and heel; Arch elastic band; Breathable mesh on the instep; Thickened ankle support; Non-slip, cushioned sole strips
Arrival time: January 2026



A-Pink/grey B-Dark green/light green C-Navy blue/orange D-White/navy blue

Crew Socks
KSO-607

Material: 87% cotton + 11% polyester fiber + 2% spandex
Size: 24-26
Feature: Thickened toe and heel; Arch elastic band; Breathable mesh on the instep; Thickened logo for ankle support; Non-slip, cushioned sole strips; Thick terry sole
Arrival time: January 2026



A-Yellow/white B-Green C-Pink D-Blue/white

Crew Socks
KSO-608W

Material: 87% cotton + 11% polyester fiber + 2% spandex
Size: 22-24
Feature: Thickened toe and heel; Breathable mesh on the instep; Thickened textured pattern on the back; Thickened anti-slip strips on the forefoot; Arch support elastic band
Arrival time: January 2026



A-Black B-Green C-Blue D-White

Crew Socks
KSO-609

Material: 82.8% cotton + 12.1% polyester fiber + 2.7% other fibers + 1.5% diene elastic fiber + 0.9% spandex
Size: 24-26
Feature: Arch elastic band; Thickened toe and heel
Arrival time: January 2026



A-Blue/white B-Pink/white C-Green/white D-Purple/white

Crew Socks
KSO-610J

Material: 82.8% cotton + 12.1% polyester fiber + 2.7% other fibers + 1.5% diene elastic fiber + 0.9% spandex
Size: 18-22
Feature: Arch elastic band; Thickened toe and heel; Non-slip, cushioned sole strips
Arrival time: January 2026



A-Blue B-Pink C-White D-Black

Crew Socks
KSO-447

Material: 87% cotton + 11% polyester fiber + 2% spandex
Size: 24-26
Feature: 7A antibacterial; Shock-absorbent; Anti-slip; Sweat-absorbent; Breathable



A-White B-Green C-Purple D-Gray

Crew Socks
KSO-402

Material: 69% cotton + 27% polyester fiber + 4% spandex
Size: 24-26
Feature: Anti-slip; Shock-absorbent; Anti-abrasive; Ankle- and toe- protective; Breathable; Comfortable



A-Black



B-White



C-Purple

Crew Socks
KSO-408

Material: 87% cotton + 11% polyester fiber + 2% spandex
Size: 24-26
Feature: Thickened; Protective; Comfortable; Highly-elastic; Tear-resistant



A-White



B-Black



C-Gray-blue



D-Navy blue

Baseball cap
KCP-01

Material: Polyester fiber
Size: 57
Feature: Lightweight; Comfortable; Breathable



A-White



B-Black



C-Gray blue



D-Navy blue

Hollow cap
KCP-02

Material: Polyester fiber
Size: 57
Feature: Top opening; Sweat-absorbent



A-Black



B-White



C-Blue



D-Yellow



E-Pink



F-Purple

Wristband
KWT-11

Material: 74% cotton+24% polyester fiber+2% spandex
Size: 8*8cm
Packing: 1pcs/box



A-Black



B-Gray



C-Green



D-Blue



E-Yellow



F-Pink

Wristband KWT-31

Material: 74% cotton+24% polyester fiber+2% spandex

Size: 8*10cm

Packing: 1pcs/box



A-White/blue



B-White/pink

Wristband for children KWT-402J

Material: 74% cotton+24% polyester fiber+2% spandex

Size: 8*8cm

Packing: 1pcs/box



A-Dark blue



B-Light blue



C-Purple

Headband KHD-402

Material: 74% cotton+24% polyester fiber+2% spandex

Size: 18*5cm

Packing: 1pcs/pack

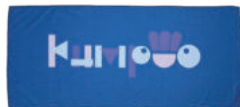

A-Navy blue



B-Blue-cyan



C-Khaki

Towel KT-401

Material: Ultra-soft fiber

Size: 40*90cm

Packing: 1pcs/pack



Insole
KI-01A

Material: EVA
 Size: 35-45
 Feature: Breathable; Anti-slip; Deodorant



Insole
KI-06

Material: Mesh + EVA
 Size: 35-45
 Feature: Wear-resistant; Breathable; Anti-slip

TAKE THE CHALLENGE

COURT EQUIPMENT SERIES

2026
KUMPOO

PRODUCT
CATALOG

COURT EQUIPMENT SERIES

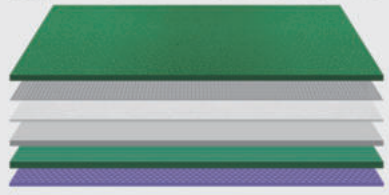
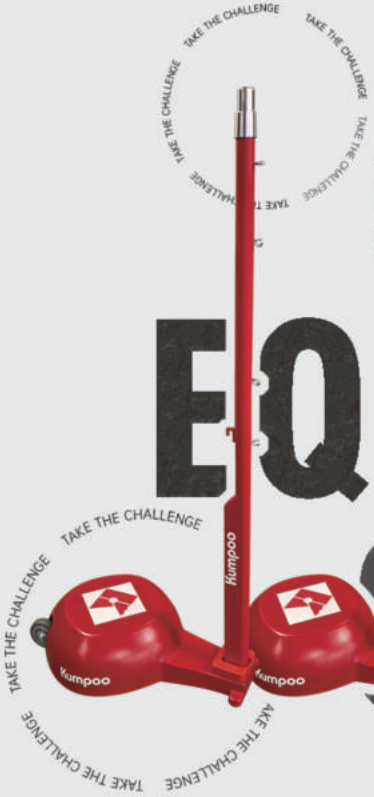

TAKE THE CHALLENGE



薰风·穿线师学院

Kumpoo Stringing Crew



To establish a professional industry standard for stringing, KUMPOO has partnered with the global authority in stringing — United States Racquet Stringers Association (USRSA) — to jointly launch the “Kumpoo Stringing Crew”.

This initiative not only highlights KUMPOO's deep influence in professional equipment and technical research, but also marks the first systematic introduction of USRSA's internationally renowned certification system into China.

Leveraging KUMPOO's advanced stringing equipment and profound understanding of racket performance, Kumpoo Stringing Crew will provide world-class, standardized training for badminton enthusiasts and professionals across China, empowering every dedicated stringer to reach new heights in their career.



KSM-5X

Description: New string gripper; Patented clamp; Semi-open drawer; Lightweight track

Color: Orange/gold/black

Voltage: 100-240V



Functions Description

1. Innovative String Gripper

It features a modular design that enables parallel stringing, effectively reducing friction and improving stringing efficiency. It also ensures uniform tension across every string, allowing the racket to deliver optimal elasticity and control.

2. Precise Tension Adjustment

It's equipped with a 0.5 lbs micro-adjustment function to meet precise tension requirements. At the same time, its overall operating speed has been significantly improved, enabling high-quality stringing to be completed in a short period of time.

3. Universal Compatibility

It's compatible with various types of strings, meeting diverse stringing needs.

4. Lightweight & Quiet

It features a lightweight track and silent clamp. It can shorten the distance to the racket while ensuring a quiet and stable operating process.

Racket Mounting System

1. Six Points Mounting System

The unique six points mounting system provides comprehensive and stable support for the racket. It is compatible with various frame shapes and sizes on the market, enabling quick and precise positioning to ensure the racket remains in optimal condition throughout the stringing process.

2. Durable Patented Clamp

The patented clamp can quickly lock onto different string gauges, offering convenient and precise. Featuring a durable alloy four-tooth dual-use design, the clamp adapts to various string types and significantly extends the service life of durable components.

Support and Storage System

1. Manual Crank Lift

The manual crank lift is simple and flexible to operate, allowing effortless height adjustment based on actual needs.

2. Thoughtful Storage

The carefully designed storage drawer features a semi-open rotating structure that keeps various tools organized without taking up extra space. It maintains tidiness while ensuring that all tools are easily accessible, effectively improving stringing efficiency.

KSM-726

Description: Curved rails; Automatic brake system; Memory function; Pneumatic adjustable pole; Pre-stretch setting

Color: Red/white

Voltage: 100-240V



Functions Description

1. Chain drive combined with high-precision pressure sensor and microcomputer processor to accurately control tension
2. Auto-manual locking switch, delay locking function
3. Optional pre-stretch functionality at 5% -20%
4. Remember up to 3 personal user settings

Racket Mounting System

1. Tension control system with true constant pull avoids any tension loss during the stringing process
2. Longer racket rail
3. Six points mounting system
4. 360 degree swivel turntable with automatic brake system
5. Suited to every kind of badminton racket, mounting poles are made of stainless steel that is anti-corrosion
6. Four racket clamps are made of aluminium alloy, anti oxidation and anti friction

Support and Storage System

1. Steel machine pole, ABS plaque
2. Pneumatic adjustable pole height from 105cm to 115cm
3. Rotary ultra-large tool storage tray
4. Hidden power connection

KSF-10

Product Features:

Excellent shock absorption and anti-slipping, fast rebound



1. Certificated by the Badminton World Federation for Grade 1.
2. Longevity with minimal wear, stable friction performance, abrasion resistance, and anti-slip.
3. Eco-optimized with 100% virgin PVC materials for superior stability and deformation resistance.

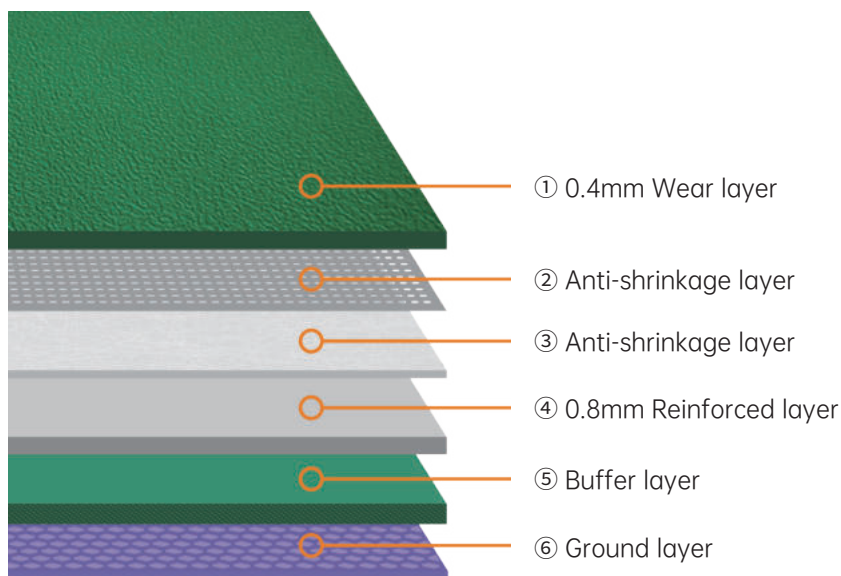

Model: KSF-10

Type: For tournament

Grade: BWF Grade 1

Color: Green

Texture: Gravel

Material: PVC

Installment method: Welding

Weight: 370kg

Size: 15*7.2m

Thickness: 4.8±0.2mm

KSF-30

Product Features:

Excellent stability and abrasion resistance



1. Certificated by the Badminton World Federation for Grade 3.
2. Great stability, abrasion resistance, and anti-slip.
3. Good shock absorption performance, offering better comfort and protection.

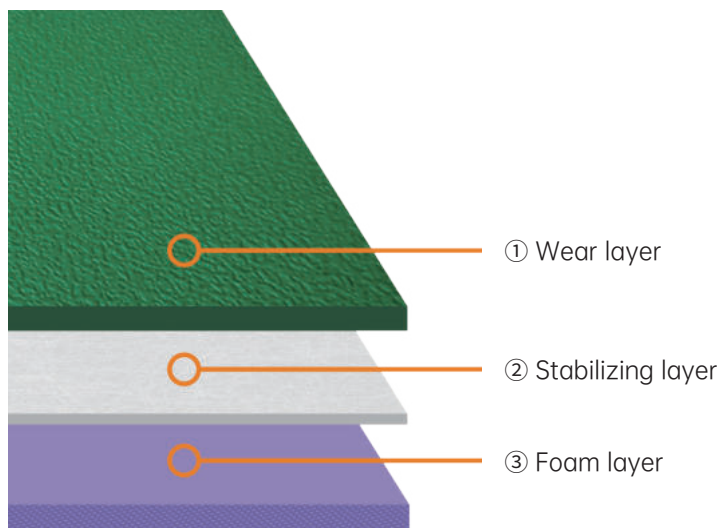

Model: KSF-30

Type: For tournament

Grade: BWF Grade 3

Color: Green

Texture: Crystal sand

Texture: PVC

Installment method: Welding

Weight: 320kg

Size: 15*7.2m

Thickness: 4.5±0.2mm

KSF-50

Product Features:

Economical and practical

1. It features a crystal-sand texture commonly used in tournament, offers excellent slip resistance.
2. The 1.2 mm wear-resistant layer enhances the surface hardness and overall durability.
3. The 3.3 mm PVC foam layer provides superior protection, reducing sports-related injuries for athletes.

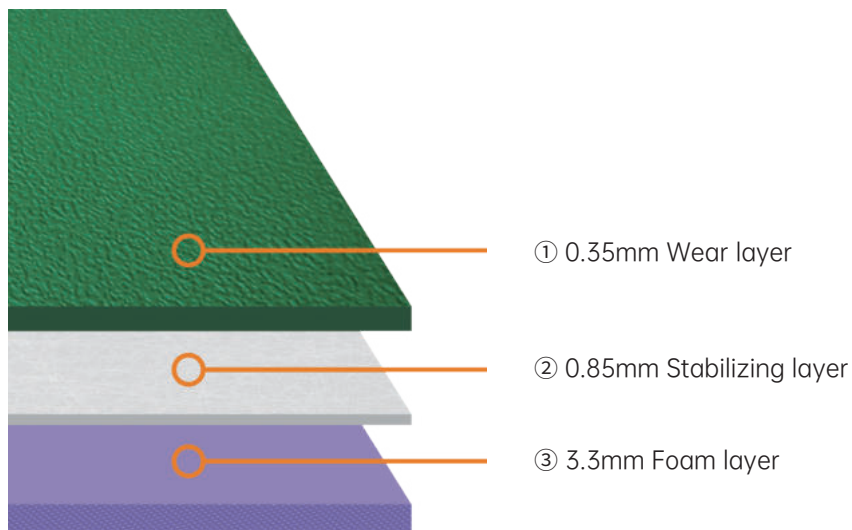

Model: KSF-50

Color: A ■ B ■ C ■ D ■ E ■

Texture: Crystal sand

Material: PVC

Weight: 340kg (4.5mm)

Dimension: 15*7.2m (15*1.8m*4pcs)

Thickness: 4.5mm/5.0mm/5.5mm/6.0mm

Installment method: Welding

KSF-70

Product Features:

Economical and practical

1. It features a lychee texture, offers excellent slip resistance.
2. The 3.5 mm PVC foam layer provides good shock absorption performance to beginners.

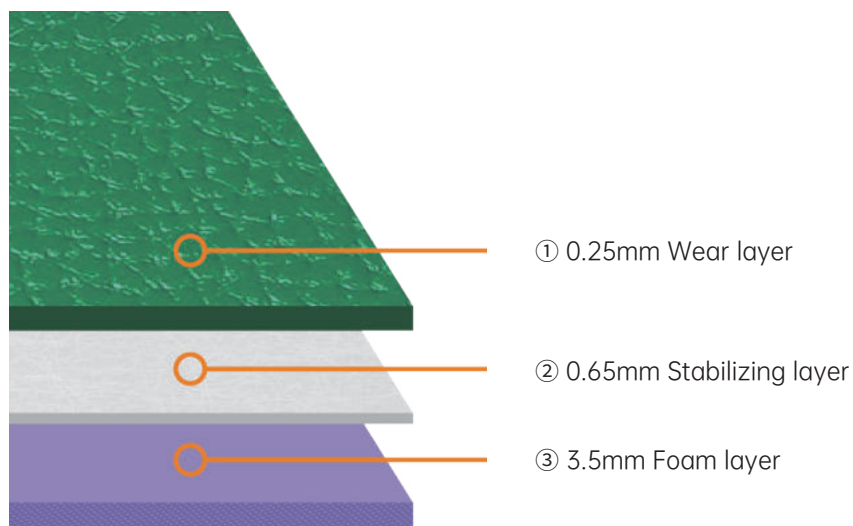

Model: KSF-70

Color: A ■ B ■ C ■ D ■ E ■

Texture: Lychee pattern

Material: PVC

Installment method: Welding

Dimension: 15*7.2m (15*1.8m*4pcs)

Thickness: 4.5mm/5.0mm/5.5mm/6.0mm

Weight: 320kg (4.5mm)

KSF-71

Product Features:

Economical and practical

1. It features a gemstone texture, offers excellent slip resistance, which is easy to clean up.
2. The 3.5 mm PVC foam layer provides good shock absorption performance to beginners.

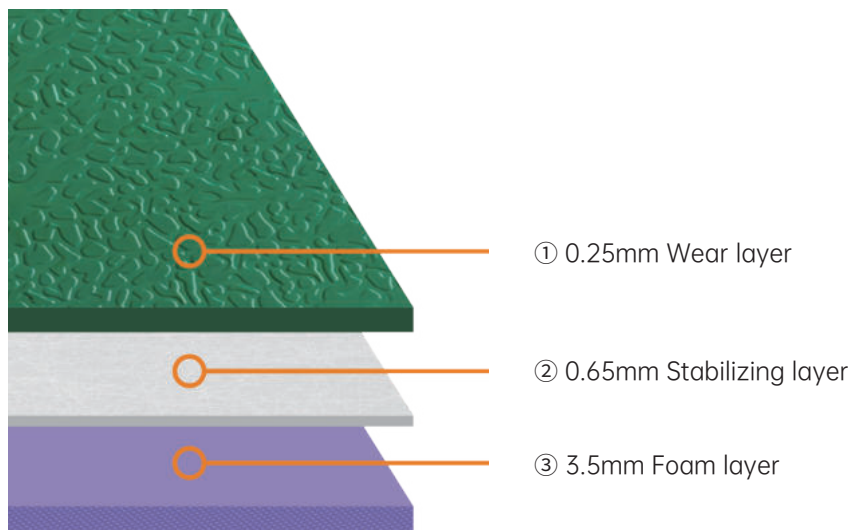

Model: KSF-71

Color: A ■ B ■ C ■ D ■ E ■

Texture: Gemstone pattern

Material: PVC

Installment method: Welding

Dimension: 15*7.2m (15*1.8m*4pcs)

Thickness: 4.5mm/5.0mm/5.5mm/6.0mm

Weight: 320kg(4.5mm)

KSF-72

Product Features:

Wear resistant & anti-slip

1. Produced using transfer-printing technology, it delivers high wood-grain clarity.
2. 0.3mm pure PVC transparent wear-resistant layer significantly extends the service life.
3. The surface features a hammered-texture embossing, making daily maintenance and cleaning more convenient.

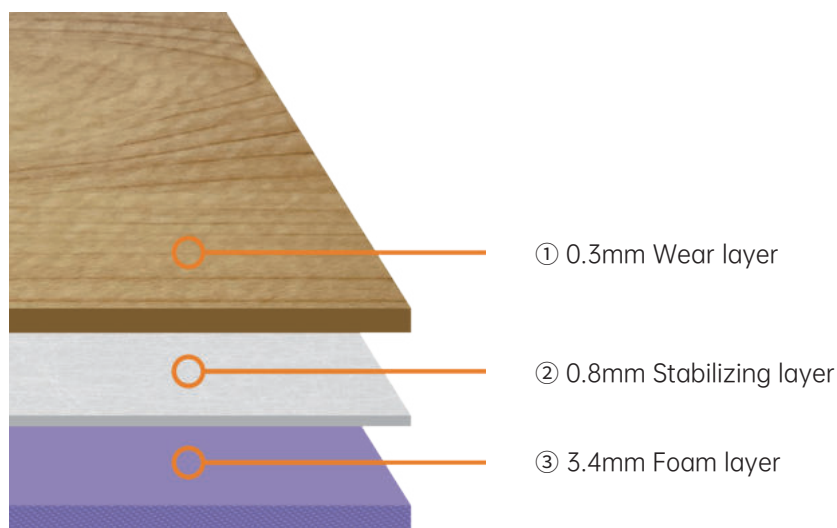

Model: KSF-72

Color: Maple

Texture: Maple

Thickness: 4.5mm

Material: PVC

Installment method: Welding

Weight: 340kg

Dimension: 15*7.2m (15*1.8m*4pcs)

KNP-10

Product Features:

Certificated net post by the Badminton World Federation, good protection, easy mobility, durable

1. The movable cast-iron base is equipped with premium silent casters for easy mobility.
2. The top sliding groove and cassette-style tensioner allow the net to be tightened effortlessly, ensuring convenient operation and preventing loosening.
3. The lower section is fitted with hardware screws to secure the net rope firmly.
4. Made from one-piece cast iron with an electrostatic powder-coated finish, the structure achieves a hardness level of 2H, offering high durability and stable performance.
5. The base includes adjustable counterweight iron blocks, allowing users to freely choose weights from 10kg to 80kg to meet different stability requirements.



Model: KNP-10 Grade: Tournament Color: Red Material: Cast-iron Installment method: Manual assembly

Weight: 180kg/set (counterweight iron blocks 80kg) Dimension: 67*45*15.8cm (base); 155cm height (post)

KNP-52

Product Features:

Professional net post, easy mobility, durable

1. The movable cast-iron base is equipped with premium silent casters for easy mobility.
2. The top features a sliding groove, along with a stainless-steel tensioner and metal crank handle, allowing the net rope to be tightened effortlessly without loosening. The inner side is equipped with stainless-steel hooks to securely fasten the net.
3. Made from one-piece cast iron with an electrostatic powder-coated finish, the structure achieves a hardness level of 2H, offering high durability and stable performance.



Model: KNP-52

Color: Red

Installment method: Manual assembly

Material: Cast-iron

Weight: 180kg/set

Dimension: 60*42*20cm (base); 155cm height (post)

KNP-51

Product Features:

Adjustable double net posts, suitable for 15cm-80cm distance between 2 courts

1. The movable cast-iron base is equipped with premium silent casters for easy mobility.
2. The top features a sliding groove, along with a stainless-steel tensioner and metal crank handle, allowing the net rope to be tightened effortlessly without loosening. The inner side is equipped with stainless-steel hooks to securely fasten the net.
3. Made from one-piece cast iron with an electrostatic powder-coated finish, the structure achieves a hardness level of 2H, offering high durability and stable performance.
4. Adjustable base is suitable for 15cm-80cm distance between 2 courts.



Model: KNP-51

Color: Red

Installment method: Manual assembly

Material: Cast-iron

Weight: 38kg/set

Dimension: 44*28*8cm (base); 155cm height (post)

KNP-64

Product Features:

General net posts, moderate weight, economical and practical

1. The movable cast-iron base is equipped with premium silent casters for easy mobility.
2. The top features a sliding groove, along with a stainless-steel tensioner and metal crank handle, allowing the net rope to be tightened effortlessly without loosening. The inner side is equipped with stainless-steel hooks to securely fasten the net.
3. Made from one-piece cast iron with an electrostatic powder-coated finish, the structure achieves a hardness level of 2H, offering high durability and stable performance.
4. High-quality ABS shell, not easily damaged, with strong load-bearing capacity.



Model: KNP-64

Color: Blue/Red

Installment method: Manual assembly

Material: ABS

Weight: 160kg/set

Dimension: 69*50*28cm (base); 155cm height (post)

KNP-62

Product Features:

Training net posts, light weight, easy mobility

1. The movable cast-iron base is equipped with premium silent casters for easy mobility.
2. The top features a sliding groove, along with a stainless-steel tensioner and metal crank handle, allowing the net rope to be tightened effortlessly without loosening. The inner side is equipped with stainless-steel hooks to securely fasten the net.
3. Made from one-piece cast iron with an electrostatic powder-coated finish, the structure achieves a hardness level of 2H, offering high durability and stable performance.
4. High-quality ABS shell, not easily damaged, with strong load-bearing capacity.



Model: KNP-62

Color: Yellow

Installment method: Manual assembly

Material: ABS

Weight: 120kg/set

Dimension: 78*37*14cm (base); 155cm height (post)

KNP-61

Product Features:

ABS unadjustable double net posts, economical and practical

1. The movable cast-iron base is equipped with premium silent casters for easy mobility.
2. The top features a sliding groove, along with a stainless-steel tensioner and metal crank handle, allowing the net rope to be tightened effortlessly without loosening. The inner side is equipped with stainless-steel hooks to securely fasten the net.
3. Made from one-piece cast iron with an electrostatic powder-coated finish, the structure achieves a hardness level of 2H, offering high durability and stable performance.
4. High-quality ABS shell, not easily damaged, with strong load-bearing capacity.
5. Unadjustable base, suitable for 60cm distance between 2 courts.

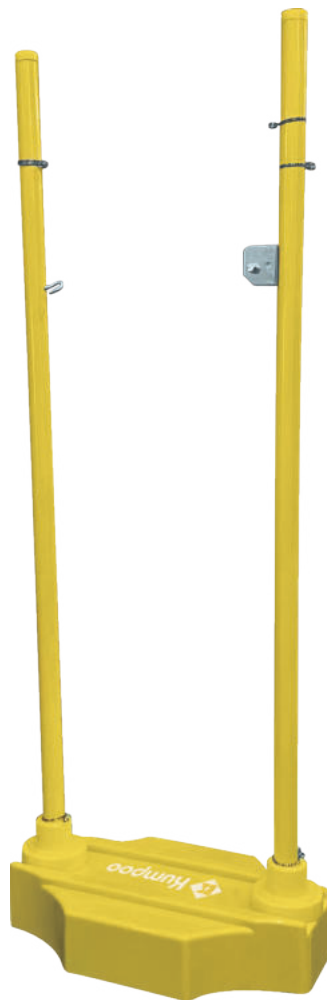

Model: KNP-61

Color: Yellow

Installment method: Manual assembly

Material: ABS

Weight: 35kg/set

Dimension: 56*35*13cm (base); 155cm height (post)

KBN-10

Product Features:

Suitable for professional tournaments

1. Precision-stitched borders prevent fraying and tearing, staying firm under powerful smashes.
2. 1.8cm mesh size with millimeter-level accuracy, fully compliant with BWF regulations.
3. Knotted construction enhances tensile and impact resistance, keeping the net tight and stable over long-term use.
4. Round metal eyelets distribute tension evenly and reduce wear, maintaining tightness through repeated setup.
5. Velcro adjustment ensures easy tightening and prevents loosening.
6. Certificated by BWF, suitable for high level tournaments.



Model: KBN-10

Color: Red/white

Material: Polyester

Weight: 0.5kg/pcs

Dimension: 6.1m*76cm, 1.8*1.8cm (mesh size)

KUC-50

Product Features:

Easy mobility, high safety factor

1. Detachable wheels allow easy movement and quick assembly, saving time and effort.
2. Main tube $\varnothing 32$ mm with 2.0 mm thickness provides strong tensile strength and long-lasting durability.
3. Hollow seats and wood-grain boards made from eco materials; ergonomic seat curvature ensures comfortable sitting and flexible extension.
4. High load-bearing capacity, wear-resistant and durable, ensuring enhanced safety.
5. Made from one-piece cast iron with an electrostatic powder-coated finish, the structure achieves a hardness level of 2H, offering high durability and stable performance.



Model: KUC-50

Color: Yellow

Material: Steel+Plastic+Wood

Weight: 30kg

Dimension: 96*68*181cm

RACKET		
Model	Material	Tarif €
2026 YEAR OF HORSE 马到功成	High strength carbon fiber	120,0
ASURA II 修罗II	New high modulus carbon fiber+Inner foaming+Nano-Resin	220,0
ASURA II SPIKE X 修罗II-锥击	New high modulus carbon fiber+Inner foaming+Nano-Resin	250,0
2300-DAREN II SP 2300国伦II SP	High modulus carbon fiber+Nano-Resin	280,0
MOUNTAINS AND RIVERS NEW 山海NEW	High modulus carbon fiber+Inner foaming	160,0
EX100	High strength carbon fiber	120,0
TWIN-ENGINE II 异能II	T800 High modulus carbon fiber+Inner foaming+Nano-Resin	145,0
AK-7 II 4U/5U	High strength carbon fiber	130,0
HOUYI III SP 厚羿III SP	High modulus carbon fiber+Graphene+Inner foaming	245,0
HOUYI III 厚羿III	High modulus carbon fiber+Graphene+Nano-Resin	220,0
WHIPBLAST K7 鞭速K7	High strength carbon fiber+Titanium alloy+Inner foaming	125,0
2300 DAREN II 国伦II	High modulus carbon fiber+Nano-Resin	275,0
2900 II	High modulus carbon fiber+Nano-Resin	225,0
RIDE THE WIND 100 乘风100	High modulus carbon fiber+Inner foaming	140,0
RIDE THE WIND S 4U 乘风S 4U	High strength carbon fiber+ Full carbon fiber	140,0
RIDE THE WIND S 6U 乘风S 6U	High strength carbon fiber+Carbon fiber+Kevlar	140,0
LORIE 10	Full carbon fiber	80,0
GF-SH 神幻	High strength carbon fiber	95,0
YANGZHOU 苏K	High strength carbon fiber	105,0
JINGZHOU 苏D	High strength carbon fiber	105,0
DREAM 梦蝶	High strength carbon fiber	95,0
PINES II 劲松II	High strength carbon fiber	125,0
QF-TY	Full carbon fiber	80,0
QF-R20	Full carbon fiber	80,0
QF-10/QF-11/QF-13	Full carbon fiber	80,0
QF-12	Full carbon fiber	80,0
KZ-HD 黑洞	Full carbon fiber	85,0
KZ-10	Full carbon fiber	85,0
MC66/MC88	Full carbon fiber	75,0
MC77	Full carbon fiber	75,0
K520PRO Pink;Blue	Full carbon fiber	140,0
K520PRO White;Black	Full carbon fiber	140,0
VELURIYAM 琉璃 White/purple;White/blue	Full carbon fiber	140,0
CA-17	Aluminum	55,0
HYPERSHOT NEX 3U/4U Orange;Blue	High strength carbon fiber+Inner foaming	105,0
HYPERSHOT HEXAGON 3U/4U Red;Purple	High strength carbon fiber	105,0

HYPER SHOT WIND 4U	High strength carbon fiber	105,0
HYPER SHOT WIND 6U	High strength carbon fiber	105,0
HYPER SHOT WIND 8U	High strength carbon fiber	105,0
CA-06	Carbon Alumini+Full carbon fiber	35,0
520A(S)/520B(S)	Carbon fiber+Resin	60,0
E30	6061 Aluminum+Carbon fiber+Resin	40,0
POPPING CANDY	Carbon fiber+Resin	40,0
LT-001	Aluminum alloy+Ferroalloy	30,0
RIDE THE WIND S.25th 6U 乘风S 6U 25周年	High strength carbon fiber	140,0
2300 DAREN.25th 2300国伦 25周年礼盒套装	High strength carbon fiber	295,0
ASURA 修罗	New high modulus carbon fiber+Inner foaming+Nano-Resin	240,0
2300 DAREN 国伦	High modulus carbon fiber	275,0
TWIN-ENGINE 异能	T700 High modulus carbon fiber+Inner foaming+Energy core	150,0
HOUYI II 厚羿II	T800 High modulus carbon fiber+Graphene+Built-in titanium wire	200,0
HOUYI 厚羿	40T High modulus carbon fiber+Graphene	200,0
E55LS/E56LS/E57LS/E58LS	Full carbon fiber	65,0
E88LS/E89LS	Full carbon fiber	70,0

SHOES

Model	Material	Tarif €
KH-G805 LITE PRO White;Light blue;White/pink	TPU+Mesh+PU	140,0
KH-G815 Black;White/silver;Green	TPU+Mesh+Fabric	160,0
KH-G826S 金戈铁马 Silver;Gold	TPU+Mesh+Fabric	180,0
KH-G826S 厚羿PRO White;White/red;Black	TPU+Mesh+Flyknit+Fitgo+Fabric+EVA	180,0
KH-G826 厚羿 White/red;White/green;Blue	TPU+Mesh+Flyknit	185,0
KH-G828 修罗 White/black;Blue	Microfiber+TPU+Mesh+Fabric+EVA	185,0
KH-G715 国伦【特别版】 Purple;Blue;Green/pink	TPU+PU+ESS	150,0
KH-G712 蝶影 Purple;Gray/blue	UHMWPE+TPU+PU+Mesh+Fabric+EVA	150,0
KH-D75 White/purple;White/black;White/blue	TPU+PU+EVA	135,0
KH-E315 White/silver;White/red;White/blue	TPU+PU+EVA	135,0
KH-E316 White/blue/orange;White/green/blue	TPU+PU+EVA	135,0
KH-E317 White/blue;White/green	PU+EVA	95,0
KH-E318 Beige/pink;White/blue	TPU+PU+EVA	95,0
KH-E319 White/blue;Gray/silver;White/purple;White/brown	PU+EVA	95,0
KH-D72PRO 琉璃 Purple;Pink;White/black	TPU+TPU+Mesh+Fabric+EVA	95,0
KH-X107 White;Black;Pink	Mesh+TPU	135,0
KH-X007 Khaki/white;White/red;Black	EVA	25,0
KH-JG826S Pink/green;Green/orange;White/red/black;White	TPU+EVA	145,0
KH-J08 White;White/blue;White/green	TPU+Mesh+Fabric+EVA	75,0
KHS-J10 White/green;White/blue	PU+EVA	75,0
KHS-J20 White/gray;White/purple;White/blue	PU+EVA	65,0

KH-G828.25th Green/pink	TPU+Mesh	190,0
KH-D72PRO.25th White/pink	TPU+Mesh	105,0
KH-T517	TPU+Mesh	145,0
APPAREL		
Model	Material	Tarif €
K261M-1226 Navy blue;Blue;Green;Pink	88% Polyester fiber+12% Spandex	40,0
K261W-1227 Navy blue;Blue;Green;Pink	88% Polyester fiber+12% Spandex	40,0
K261M-1154 Red;Blue;Dark blue;White	100% Polyester fiber	42,0
K261U-4222 Red;Blue;Dark blue;White	100% Polyester fiber	42,0
K261W-1155 Red;Blue;Dark blue;White	100% Polyester fiber	42,0
K261M-1156 Rose;Blue	88% Polyester fiber+12% Spandex	45,0
K261M-4057 Rose;Blue	88% Polyester fiber+12% Spandex	45,0
K261W-1158 Rose;Blue	88% Polyester fiber+12% Spandex	45,0
K261M-1566 Pink;Dark blue	100% Polyester fiber	42,0
K261W-1567 Pink;Dark blue	100% Polyester fiber	42,0
K261M-1148 Green;Red	88% Polyester fiber+12% Spandex	45,0
K261W-1149 Green;Red	88% Polyester fiber+12% Spandex	45,0
K261M-1150 White;Green;Blue	100% Polyester fiber	42,0
K261W-1151 White;Green;Blue	100% Polyester fiber	42,0
K261M-1169 Blue;Pink	86% Polyester fiber+14% Spandex	42,0
K261W-1170 Blue;Pink	86% Polyester fiber+14% Spandex	42,0
K241M-1038 White;Red;Blue	87% Polyester fiber+13% Spandex	40,0
K241M-4038 White;Red;Blue	87% Polyester fiber+13% Spandex	40,0
K241W-1038 White;Red;Blue	87% Polyester fiber+13% Spandex	42,0
K261U-2059 White;Red;Blue;Black	95% Polyester fiber+5% Spandex	42,0
K261U-2061 White;Black;Green;Blue	90% Polyester fiber+10% Spandex	22,0
K261U-2207 Pink;Yellow;White;Green	89% Polyester fiber+11% Spandex	22,0
K261W-7549 White;Red;Black;Blue	100% Polyester fiber	22,0
K261W-7181 Green;White;Red;Black	96.8% Polyester fiber+3.2% Spandex	40,0
K261W-7060 White;Black	88% Polyester fiber+12% Spandex	45,0
K261W-7063 Rose;Blue;White;Pink	88% Polyester fiber+12% Spandex	42,0
K261M-1731 Blue;Dark green;Light green	89.5% Polyester fiber+10.5% Spandex	40,0
K261W-1732 Blue;Dark green;Light green	90% Polyester fiber+10% Spandex	40,0
K261W-1730 White;Rose;Blue;Brown	88.1% Polyester fiber+11.9% Spandex	35,0
K261W-1729 Black;White;Orange;Pink	89.5% Polyester fiber+10.5% Spandex	35,0
K261W-9727 Pink;Blue;White;Orange	84.7% Polyester fiber+15.3% Spandex	42,0
K251U-5064 Black;White	90% Polyester fiber+10% Spandex	65,0
K251M-5221 Black	86% Nylon+14% Spandex	75,0
K261U-1217 Black;White	100% Polyester fiber	25,0

K261U-4223 Green;Blue	100% Polyester fiber	20,0
K261U-1224 Green;Blue	100% Polyester fiber	20,0
K261U-4016 Black;Gray	100% Polyester fiber	25,0
K261M-3170 White;Black	77.8% Nylon+22.2% Spandex	25,0
K251U-6066 White;Black	90% Polyester fiber+10% Spandex	30,0
K251M-6176 Navy blue	90.6% Nylon+9.4% Spandex	30,0
K261U-1717 Light blue;Pink;Green;Brown;White	100% Polyester fiber	30,0
K261U-1720 Blue;Red;Green;Brown;Beige	100% Polyester fiber	30,0
K261U-1718 Black;White;Pink;Green	100% Polyester fiber	30,0
K261M-1171 White;Black	100% Cotton	40,0
K261U-1024 Gray;Black	100% Polyester fiber	42,0
K261M-1240 White;Green;Black	74.2% Cotton+25.8 Sorona	42,0
K261M-1173 White;Black	100% Cotton	40,0
K261W-1234 Blue;White;Black	83.8% Nylon + 16.2% Spandex	40,0
K261W-1558 Blue;Navy blue;Purple	89.9% Polyester fiber+10.1% Spandex	20,0
K261W-1140 Gray;Black	46.2%Cotton+44.9%Viscose+8.9% Spandex	42,0
K261W-4122 Gray;Dark gray	46.2%Cotton+44.9%Viscose+8.9% Spandex	42,0
K261W-7182 Red;White;Black;Blue	96.8% Polyester fiber+3.2% Spandex	42,0
K251W-7225 Gray;Black	46.2%Cotton+46%Viscose+8% Spandex	42,0
K261W-7183 Black;White	88.6% Polyester fiber+11.4% Spandex	42,0
K261W-7226 Black;White	90.5% Polyester fiber+9.5% Spandex	42,0
K251M-5224 Navy blue	100% Polyester fiber	42,0
K261M-1531.25th Green;Pink	100% Polyester fiber	42,0
K261W-1532.25th Green;Pink	100% Polyester fiber	42,0
K261U-1528.25th Green;Beige	100% Cotton	42,0
K261U-5545.25th Green;Beige	90.6% Nylon + 9.4% Spandex	70,0
K261U-2540.25th Beige	89.4% Nylon + 10.6% Spandex	40,0
K261W-7542.25th Beige	90.2% Nylon + 9.8% Spandex	40,0
K261U-6546.25th Beige	89.4% Nylon + 10.6% Spandex	40,0
K261K-1197 Blue;Green	90.7% Polyester fiber+7.3% Spandex	35,0
K253K-1118 Pink;Green	100% Polyester fiber	35,0
K253M-1116 Pink;Green	100% Polyester fiber	35,0
K253W-1117 Pink;Green	100% Polyester fiber	35,0
K253K-1147 Blue;Green;Pink	100% Polyester fiber	40,0
K253M-1987 Blue;Green;Pink	100% Polyester fiber	40,0
K253W-1988 Blue;Green;Pink	100% Polyester fiber	40,0
K253K-2004 Navy;Green	95% Polyester fiber+5% Spandex	40,0
K253U-2002 Navy;Green	95% Polyester fiber+5% Spandex	40,0
K253W-7999 White;Blue;Green	84.8%Polyester fiber+15.2%Spandex	40,0
K261K-7227 Puppel;Blue;Black	90.5%Polyester fiber+9.5%Spandex	40,0
K253U-2116 Black	90.5%Polyester fiber+9.5%Spandex	35,0
K253U-2117 Black	90.5%Polyester fiber+9.5%Spandex	35,0

K261K-2208 Pink;Yellow;White;Green	89%Polyester fiber+11%Spandex	35,0
K261K-1205 Yellow;Purple;Pink	100% Polyester fiber	35,0
K261U-1204 Yellow;Purple;Pink	100% Polyester fiber	35,0
KWX-3002K Purple;Black	100% Polyester fiber	35,0
KWX-3002U Purple;Black	100% Polyester fiber	35,0
K261K-1186 White;Pink;Purple	94%Polyester fiber+6%Spandex	30,0
K253K-5004 Green;Blue	90%Polyester fiber+10%Spandex	65,0
K253U-5003 Green;Blue	90%Polyester fiber+10%Spandex	70,0
K253K-3999 Navy;Green	100% Cotton	45,0
K253U-3998 Navy;Green	100% Cotton	45,0
K261M-1172 White;Black	100% Polyester fiber	30,0
K261M-1174 White;green;White/blue;Green	100% Polyester fiber	30,0
K261W-4232 White;Purple;Blue	100% Polyester fiber	42,0
K261M-1660 White	100% Polyester fiber	42,0
K261M-4659 White	100% Polyester fiber	42,0
K261W-4550 Blue;Green;White	100% Polyester fiber	40,0
K261W-7559 Blue;Navy;Purple	100% Polyester fiber	42,0
K261K-2188 Green;Blue	100% Polyester fiber	30,0
K261M-2175 Green;Blue	100% Polyester fiber	42,0
K261W-8185 White;Black	100% Polyester fiber	50,0
K261M-2661 Blue;Navy;Black	100% Polyester fiber	45,0
K261K-8231 White;Blue	100% Polyester fiber	45,0
K261W-5177 White;Black;Blue	100% Polyester fiber	55,0
K261M-5655 Blue;Navy;Green	100% Polyester fiber	70,0

BAG

Model	Material	Tarif €
KB-672 White/orange;White/green;Purple	Fabric	65,0
KB-523 Blue/orange;Purple/green	Fabric	65,0
KB-671 Blue;Purple	Fabric	60,0
KB-566.25th	Synthetic leather+Fabric	65,0
KB-5212.25th	Synthetic leather+Fabric	65,0
KB-631 Purple/white;Black/white	Synthetic leather+Fabric	35,0
KB-632 White;White/yellow;White/blue	Fabric	68,0
KB-634 White/blue;Beige/black	Fabric	65,0
KB-661 Black/white;Beige/khaki	Fabric	70,0
KB-662 White/black;White/purple;White/blue	Synthetic leather+Fabric	70,0
KB-663 Silver/gray;White/green;White/khaki	Synthetic leather+Fabric	70,0
KB-691 White/Khaki;White/red	Synthetic leather+Fabric	72,0
KB-664 Beige/khaki;Beige/red;White/navy	Fabric	70,0
KB-665 Black/orange	Synthetic leather+Fabric	65,0

KB-621 White/yellow;White;White/blue	Fabric	60,0
KB-623 Silver;Green/white;Pink/white	DuPont Tyvek fabric	65,0
KB-622 Beige/khaki;Beige/red;White/navy	Fabric	55,0
KB-624 White/gray;White/black;White/green/yellow	Synthetic leather+Fabric	65,0
KB-611 White;White/yellow;White/blue	Fabric	35,0
KB-612 Silver;Green/white;Pink/white	DuPont Tyvek fabric	35,0
KB-613 Silver;Green/white;Pink/white	DuPont Tyvek fabric	20,0
KB-692	TPU leather+Double-ply yarn	95,0

GRIP

Model	Material	Tarif €
KG-17.25th(2pcs/pack)	Polyurethane+Non-woven fabric	4,0
KG-13(3pcs/pack)	Polyurethane+Non-woven fabric	6,0
KG-12(1pcs/pack)	Cotton	3,0
KG-12(10m/coil)	Cotton	25,0
KG-30 (2pcs/pack)	Polyurethane+Non-woven fabric	4,0
KG-30(9pcs/pack)	Polyurethane+Non-woven fabric	15,0
KG-301(60pcs/barrel-single color)	Polyurethane+Cotton	80,0
KG-302 (60pcs/barrel-single/mixed color)	Polyurethane+Microfiber	90,0

SOCKS

Model	Material	Tarif €
KSO-507.25th Green;Pink	87% Cotton+11% Polyester fiber+2% Spandex	8,0
KSO-601W White/blue;White/purple;White/pink	82.8% Cotton+12.1% Polyester fiber+0.9% Spandex	9,0
KSO-602W White;blue;Pink	82.8% Cotton+12.1% Polyester fiber+0.9% Spandex	9,0
KSO-603 Black/white;Green/white	87% Cotton+11% Polyester fiber+2% Spandex	8,0
KSO-604 Pink;Purple	87% Cotton+11% Polyester fiber+2% Spandex	6,0
KSO-605J Green;Purple;Yellow;Blue	87% Cotton+11% Polyester fiber+2% Spandex	6,0
KSO-606 Black/orange;White/red;Beige/blue;Pink/purple	87% Cotton+11% Polyester fiber+2% Spandex	8,0
KSO-607 Gray/pink;Dark green/light green;Navy/orange;White/navy	87% Cotton+11% Polyester fiber+2% Spandex	9,0
KSO-608W White/yellow;Green;Pink;White/blue	87% Cotton+11% Polyester fiber+2% Spandex	9,0
KSO-609 Black;Green;Blue;White	82.8% Cotton+12.1% Polyester fiber+0.9% Spandex	8,0
KSO-610J White/blue;White/pink;White/green;White/purple	82.8% Cotton+12.1% Polyester fiber+0.9% Spandex	8,0
KSO-447 Blue;Pink;White;Black	87% Cotton+11% Polyester fiber+2% Spandex	10,0
KSO-402 White;Green;Purple;Gray	69% Cotton+27% Polyester fiber+4% Spandex	8,0
KSO-408 Black;White; Purple	87% Cotton+11% Polyester fiber+2% Spandex	8,0

PROTECTOR

Model	Material	Tarif €
KWT-504.25th Green;Pink	80% Cotton + 18% Polyester + 2% Spandex	10,0

KWT-11	74% Cotton+24% Polyester fiber+2% Spandex	10,0
KWT-31	74% Cotton+24% Polyester fiber+2% Spandex	10,0
KWT-402J	74% Cotton+24% Polyester fiber+2% Spandex	10,0

HEADBAND

Model	Material	Tarif €
KHD-5010.25th Green;Pink	80% Cotton + 18% Polyester + 2% Spandex	4,0
KHD-402	74% Cotton+24% Polyester fiber+2% Spandex	2,0

TOWEL

Model	Material	Tarif €
KT-517.25th Green;Pink	100% Microfiber	10,0
KT-401	Ultra-soft fiber	10,0

INSOLE

Model	Material	Tarif €
KI-01A	EVA	7,0
KI-06	Mesh+EVA	10,0

